

OPERATORS MANUAL

THE VAULT



PLEASE NOTE:

Read this manual **BEFORE** operating the machine.
Keep this manual for your reference.
Go to www.LAIGames.com click on Support to register your
games and receive future updates.



LAI Games

Correspondence regarding this machine should be addressed to your closest LAI Games office, or LAI Games Distributor.
For contact details, refer to the back page of this manual.

© LAI Games

Copyright Notice:

Authorization is hereby provided to you to copy this manual in its entirety provided such copies are used for non-commercial purposes and solely for use with LAI Games products. This authorization is specifically conditioned to include all legends, copyright, proprietary and other notices which appear herein are unaltered on any and all copies you make.

LAI Games

sales@laigames.com www.laigames.com

LAI Games Note

Dear Customer,

Keep up to date with new software updates or Service Bulletins for this game.

Check our website at www.laigames.com and click on Support, where you will find links to all the Bulletins and Software updates to keep your game in top working order.

Thanks,



Table of Contents

SAFETY PRECAUTIONS.....	7
SAFETY LABELS	8
FUUSE	9
BACK DOOR.....	10
INSIDE CABINET.....	11
INTRODUCTION.....	12
DESCRIPTION.....	12
PACKAGING	12
CONTENTS.....	12
SPECIFICATIONS	12
DIMENSIONS	12
ELECTRIC SUPPLY.....	12
CONTENTS DETAILED	13
ASSEMBLY	15
GAMEPLAY AND MODES.....	17
HOW TO PLAY	17
THREAT LEVEL	17
ATTRACT MODE	17
PLAY MODE	17
OPERATION	18
GAME SETTINGS.....	18
GAME SETTINGS DETAILED	19
AUDITS	21
INPUT AND OUTPUT TESTS	23
OUTPUT TESTS	23
INPUT TESTS.....	23
RUN TESTS.....	23
HISTORY	24
MAJOR WIN HISTORY.....	24
GAME HISTORY	24
CALIBRATION.....	24
CHANGE STICKER RANGE	25
RESET TO DEFAULT.....	25
ERRORS.....	26
SECTION A: SERVICE INSTRUCTIONS.....	28
LOCATING AND ACCESSING PARTS	28

CABINET FRONT	28
CABINET REAR.....	29
OPERATOR PANEL – SERVICE CONTROLS.....	29
PARTS DESCRIPTION	30
HEADER DISPLAY	30
SPEAKERS	30
COUNTERS.....	30
BUTTONS.....	30
VOLUME KNOB.....	30
COIN MECHANISM/BILL ACCEPTOR/CARD SYSTEM	30
TICKET MECHS.....	30
REEL MECHS	30
POWER INLET/MAINS SWITCH.....	30
POWER SUPPLIES	31
LAMPS	31
MAINTENANCE.....	31
EXTERIOR.....	31
INTERIOR	31
SECTION B: TECHNICAL DETAILS	32
POWER SUPPLY	32
COIN OPTIONS REFERENCE GUIDE.....	33
UNIVERSAL CARD LINK CONNECTION	33
TICKET MECHANISMS.....	34
WIRING DIAGRAMS.....	34
MECHANICAL ILLUSTRATIONS	49
FINAL ASSEMBLY	49
MAIN CABINET ASSEMBLY	50
HEADER ASSEMBLY	51
CABINET FRONT ASSEMBLY	52
REEL MECHS ASSEMBLY	53
PCB PANEL ASSEMBLY.....	54
CONTROL PANEL ASSEMBLY	54
DB BOX ASSEMBLY	55
OPERATOR PANEL ASSEMBLY	55
CASH BOX ASSEMBLY.....	56
SPEAKER ASSEMBLY	56
LIFE LIGHT BOX ASSEMBLY.....	57

POWER SUPPLY ASSEMBLY	57
KICK PLATE ASSEMBLY	58
RELAY 12VDC ASSEMBLY.....	58
COIN DBA PLATE ASSEMBLY	59
BACK DOOR ASSEMBLY	59
COIN DOOR ASSEMBLY	60
TICKET DOOR ASSEMBLY.....	61

SAFETY PRECAUTIONS

The following safety precautions and advisories are used throughout this manual and are defined as follows.

* WARNING! *

Disregarding this text could result in **serious injury**.

* CAUTION! *

Disregarding this text could result in damage to the machine.

* NOTE! *

An advisory text to hint or help understand.



BE SURE TO READ THE FOLLOWING

* WARNING! *

Always turn **OFF** Mains AC power and unplug the game before opening or replacing any parts.

Always grasp the plug, not the line cord, when unplugging the game from an electrical outlet.

Always connect the Game Cabinet to a grounded electrical outlet with a securely connected ground line.

Do Not install the Game Cabinet outdoors or in areas of high humidity, direct water contact, dust, high heat or extreme cold.

Do Not install the Game Cabinet in areas that would present an obstacle in case of an emergency, i.e. near fire equipment or emergency exits.

* CAUTION! *

Always use a Digital Multimeter, logic tester or oscilloscope for testing integrated circuit (IC) logic PC boards. The use of a continuity tester is not permitted.

Do Not connect or disconnect any of the integrated circuit (IC) logic PC boards while the power is **ON**.

Do Not use any fuse that does not meet the specified rating.

Do Not subject the game cabinet to extreme temperature variations. Reliability of electrical components deteriorates rapidly over 60 °C.

SAFETY LABELS



CAUTION
For continued protection against risk of fire, replace only with a fuse of the same type and having same electrical rating.



CAUTION
For continued protection against risk of fire, replace only with a fuse of the same type and having same electrical rating.

Fuse Power



DANGER
Electric Shock Hazard. Disconnect of power before servicing.

WARNING
Shock Hazard. Do NOT open. Refer servicing to service personnel.

Back Door



WARNING
Suitable For Indoor Use Only.

Bellow Name Plate



DB Box



DBA Cable

DANGER
Electric Shock Hazard. Disconnect of power before servicing.

WARNING
Shock Hazard. Do NOT open. Refer servicing to service personnel.



Inside Ticket Door

DANGER
Electric Shock Hazard. Disconnect of power before servicing.

WARNING
Shock Hazard. Do NOT open. Refer servicing to service personnel.

FUSE



	CAUTION For continued protection against risk of fire, replace only with a fuse of the same type and having same electrical rating.
--	--



	CAUTION For continued protection against risk of fire, replace only with a fuse of the same type and having same electrical rating.
---	--

BACK DOOR



	⚠ DANGER Electric Shock Hazard. Disconnect all power before servicing.
--	---

	⚠ WARNING Shock Hazard. Do NOT open. Refer servicing to service personnel.
---	--

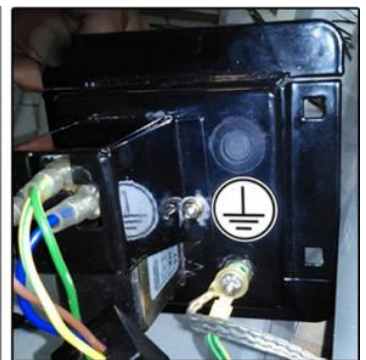

	⚠ WARNING Suitable For Indoor Use Only.
---	---

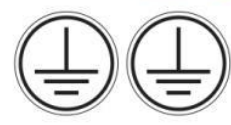

INSIDE CABINET



	⚠ DANGER Electric Shock Hazard. Disconnect all power before servicing.		⚠ WARNING Shock Hazard. Do NOT open. Refer servicing to service personnel.
---	--	---	---



	⚠ DANGER Electric Shock Hazard. Disconnect all power before servicing.		⚠ WARNING Shock Hazard. Do NOT open. Refer servicing to service personnel.
---	--	---	---

INTRODUCTION

Congratulations on your purchase of **The Vault** by LAI Games. We hope you take the time to read this manual and learn about the many features and user-friendly adjustments that can be made to fine-tune the game for maximum earning potential.

DESCRIPTION

The Vault 2 is a skill based, safe cracking themed game. Players must try and break into the safe by stopping each spinning reel in the blue section. If they can stop all five reels in the blue, they unlock the safe and win the major prize. If they lock in the first three reels correctly, they can choose to take the minor prize and end the game, or continue on to try and unlock the safe for the major prize. The security threat level will rise every time the player stops the reel on the red section, eventually reaching max and locking the player out of The Vault, causing them to lose the game.

PACKAGING

CONTENTS

- The Vault cabinet
- Operator Manual
- Header
- Kickstand
- 8 pieces M6 x 20mm
- 4mm Allen key
- 2 x coin door keys
- IEC Power Cord
- Parts & Accessories

SPECIFICATIONS

DIMENSIONS

- Weight: 180kg (396.83lb) (excluding packaging)
- Weight: 200kg (440.93lb) (including packaging)
- Height: 2486mm (97.87") (including header)
- Width: 1140mm (44.88")
- Length: 642mm (25.28")
- Power: Maximum 350W





ELECTRIC SUPPLY

The game can operate on a universal mains input voltage between 88-264VAC 50/60Hz single phase. The supply must be a three wire grounded supply. Adjustment screws are available for fine-tuning the output voltage.

LOCATION REQUIREMENTS

- Ambient temperature: 5C - 40C
- Ambient humidity: Low
- Ambient U.V. radiation: Very low
- Vibrations level: Low

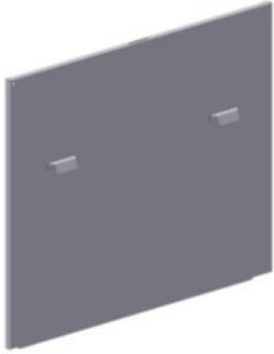
CONTENTS DETAILED

	
<p>Main Cabinet</p>	<p>Header</p>
	
<p>Kickstand</p>	<p>Back Door</p>
	
<p>M6 x 20mm bolts and washers, 8 Pieces</p>	<p>Allen key 4mm</p>

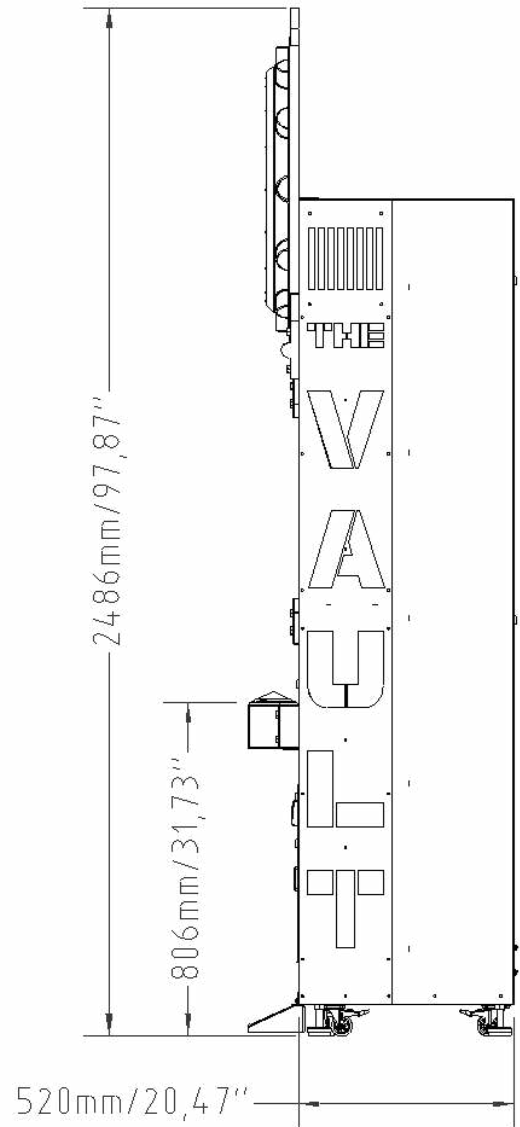
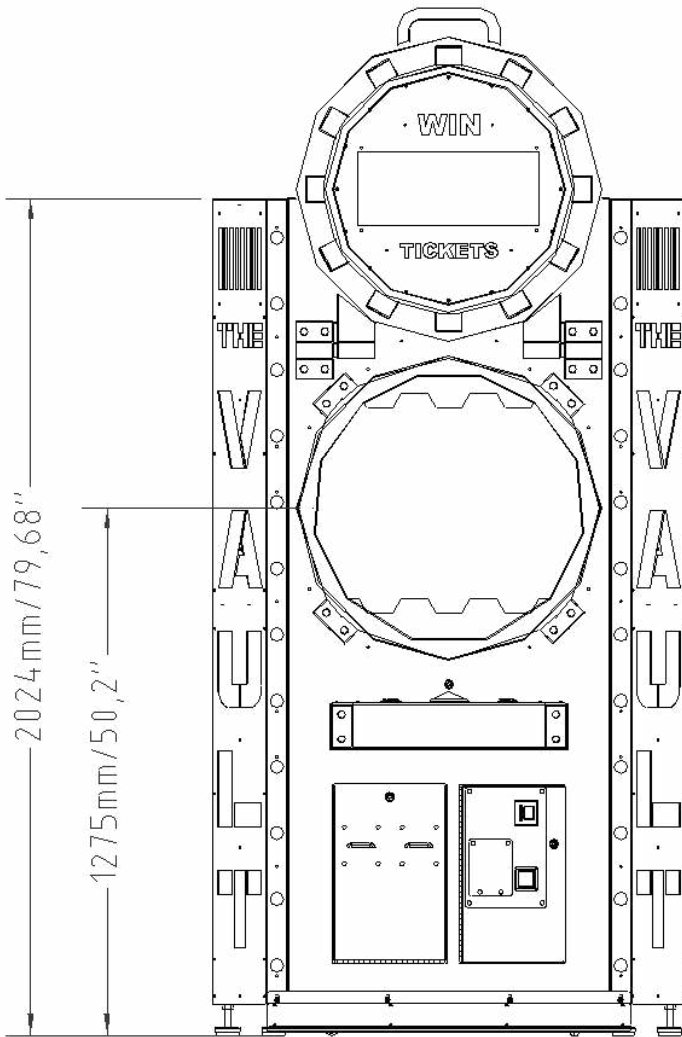
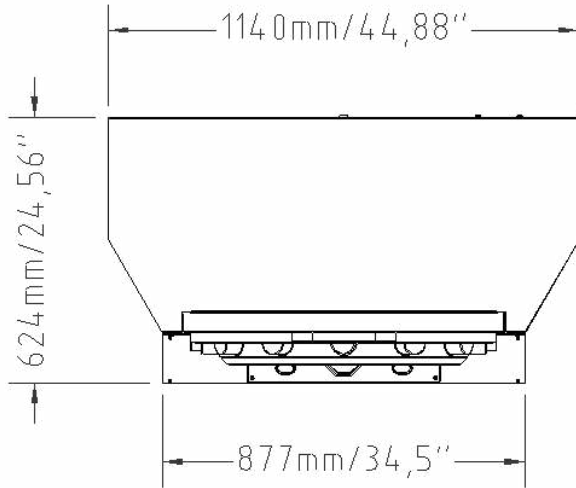

ASSEMBLY

KICKSTAND INSTALLATION

Place the kickstand on the floor in front of the cabinet.

Attach it using 4 of the M6 x 20mm bolts supplied, as shown in the image to the right.

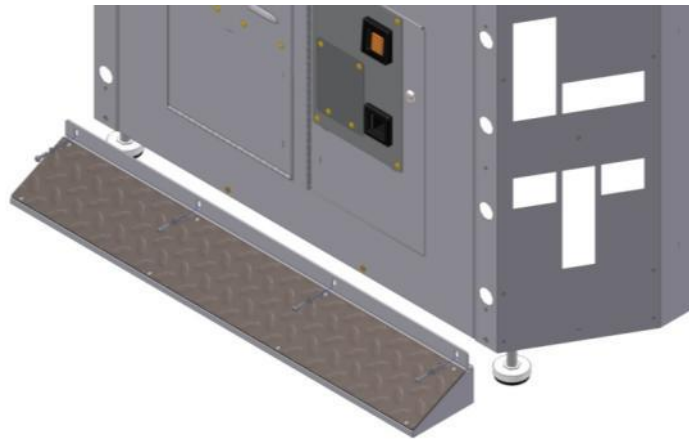

HEADER INSTALLATION

STEP 1

Position the header at the top front of the cabinet, and join the connector. Hook the header onto the tabs, via the slots on the back of the header.

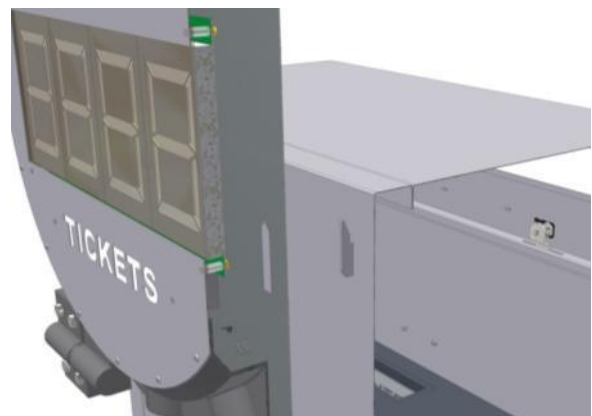
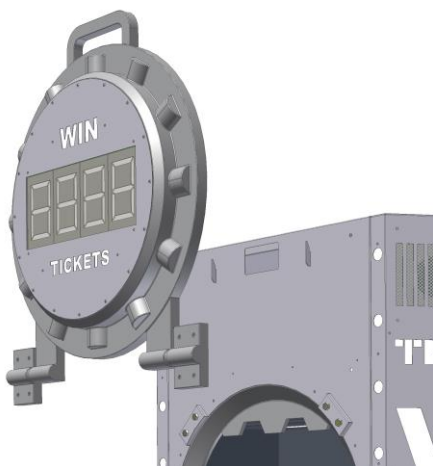

STEP 2

Open upper back door.



STEP 3

Securely fasten the header to the cabinet using 4 x M6 bolts as indicated.

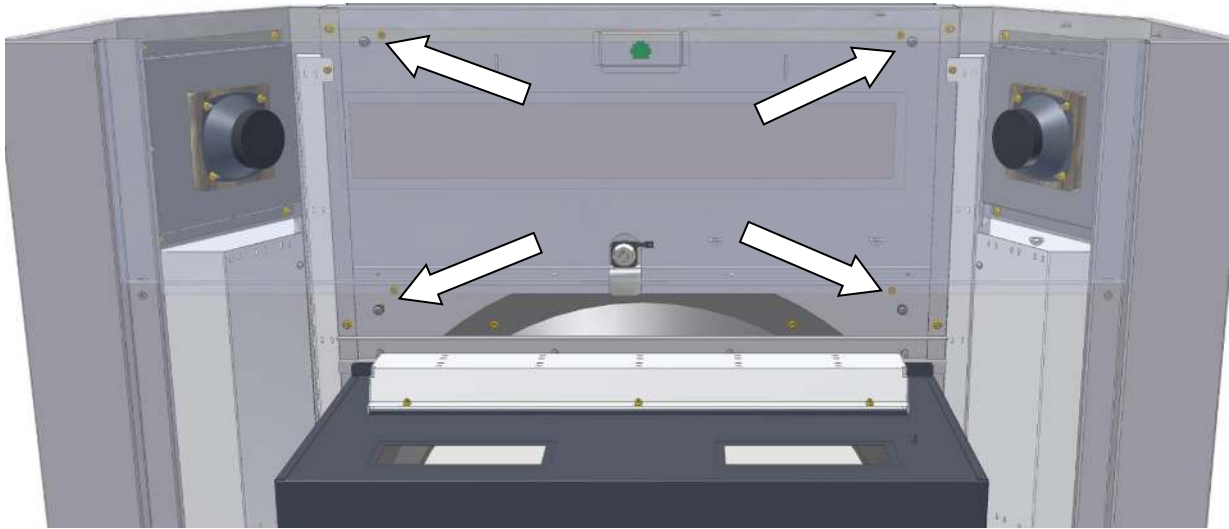

STEP 4

Close upper back door.



GAMEPLAY AND MODES

HOW TO PLAY

- Pay to play
- Press stop to play the game
- Press stop to stop the first reel mech in the blue section of the reel
- Stop on blue and move to the next reel
- Stop on red and increase the threat level
- Repeat until minor prize reel is reached
- Take the minor prize and end the game
- OR
- Forfeit the minor prize and continue playing
- IF continue, keep stopping the reel on blue
- Reach the final reel
- Stop on blue and win the major prize
- OR
- Stop on red and lose the game

THREAT LEVEL

Every time the player stops the reel on red, the security threat level rises. The threat level can rise three times before the alarm is triggered and the player is locked out of The Vault, losing the game. As the player gets closer to the major prize reel, the threat level starts to rise on its own whether or not the player makes a mistake. By the time the player reaches the final reel, the threat level has risen to the point where the player gets only one chance at winning the Major Prize.

ATTRACT MODE

PLAY MODE

The Vault has two play modes. The standard *Coin Play* mode, where a coin or coins are inserted, or *Free Play* mode, where no coins are necessary.

COIN PLAY

Coin Play mode is entered from *Attract mode*, by inserting coins in any of the two coin slots on the front of the machine cabinet, then following the instructions in the “How to Play” section.

FREE PLAY

Free play can be set in one of three ways:

- Entering the operator menu by pressing the red TEST button, then entering the game settings. From here, enter free play settings and turn free play mode on.
- For a single free game, just press the green SERVICE button once.
- Push and hold the green SERVICE button for 5 seconds. This is a temporary free mode, and the game will return to normal when reset.

OPERATION

GAME SETTINGS

No	Name	Range	Default
1	Coin 1 Number of Coins	1 - 20	1
2	Coin 1 Games per Credit	1 - 10	1
3	Coin 1 Bonus Credits	Off, On	Off
3-1	Coin 1, Level 1, Number of Coins	Off, 1 - 99	Off
3-2	Coin 1, Level 1, Number of Bonus Credits	Off, 1 - 99	Off
3-3	Coin 1, Level 2, Number of Coins	Off, 1 - 99	Off
3-4	Coin 1, Level 2, Number of Bonus Credits	Off, 1 - 99	Off
3-5	Coin 1, Level 3, Number of Coins	Off, 1 - 99	Off
3-6	Coin 1, Level 3, Number of Bonus Credits	Off, 1 - 99	Off
4	Coin 2 Number of Coins	1 - 20	1
5	Coin 2 Games per Credit	1 - 10	1
6	Coin 2 Bonus Credits	Off, On	Off
6-1	Coin 2, Level 1, Number of Coins	Off, 1 - 99	Off
6-2	Coin 2, Level 1, Number of Bonus Credits	Off, 1 - 99	Off
6-3	Coin 2, Level 2, Number of Coins	Off, 1 - 99	Off
6-4	Coin 2, Level 2, Number of Bonus Credits	Off, 1 - 99	Off
6-5	Coin 2, Level 3, Number of Coins	Off, 1 - 99	Off
6-6	Coin 2, Level 3, Number of Bonus Credits	Off, 1 - 99	Off
7	Common Coin	On/Off	Off
8	Attract Sound	Off, 1m, 2m, 5m, 10m, 20m, 30m	1 minute
9	Error Message	Display & Audio, Audio Only, Display Only, Off	Display & Audio
10	Free mode	On/Off	Off

11	Vend Prizes in Free Play	On/Off	Off
12	Prize Type	Tic/ Coupon	Tickets
13	Number of Mercy Prizes	Off, 5, 10, 15, 20	5
14	Mercy Payout Time	Before/After	Before
15	Minor Prizes	Off - 100	30
16	All Reels Running in Game play	Off / On	On
17	Reel Timeout	30 – 60 seconds	30 seconds
18	Call Attendant on Jackpot	Off, On	Off
19	Current Jackpot Payout	1 - 9999	100
20	Difficulty	1-50	50
21	Payment Type	Coins, Card	Coins

GAME SETTINGS DETAILED

- **1 = Coin 1 Number of Coins** (Default 1) (Adjustable 1 – 20)
Sets the number of coins that need to be inserted in exchange for each game credit.
- **2 = Coin 1 Games Per Credit** (Default 1) (Adjustable 1 – 10)
Sets the number of games granted for each credit.
- **3 = Coin 1 Bonus Credits** (Default Off) (Adjustable On or Off)
Turn on the first level of bonus credits. Turning this setting on, will activate settings P03-1 to P03-2.
- **3 - 1 = Coin 1, Level 1, Number of Coins** (Default Off) (Adjustable Off, 1 - 99)
This sets the number of coins that need to be inserted into coin mechanism 1 to reach the bonus credit level 1. This setting is only active if P03 is active.
- **3 - 2 = Coin 1, Level 1, Number of Bonus Credits** (Default Off) (Adjustable Off, 1 - 99)
This sets the number of bonus credits that are given when credit level 1 is reached. This is the number of bonus credits given, on top of what has been paid for. This setting is only active if P03 is active.
- **3 - 3 = Coin 1, Level 2, Number of Coins** (Default Off) (Adjustable Off, 1 - 99)
This sets the number of coins that need to be inserted into coin mechanism 1 to reach the bonus credit level 2. This setting is only active if P03-1 and P03-2 are active.

- **3 - 4 = Coin 1, Level 2, Number of Bonus Credits** (Default Off) (Adjustable Off, 1 - 99)
This sets the number of bonus credits that are given when credit level 2 is reached. This is the number of bonus credits given, on top of what has been paid for. This setting is only active if P03-1 and P03-2 are active.
- **3 - 5 = Coin 1, Level 3, Number of Coins** (Default Off) (Adjustable Off, 1 - 99)
This sets the number of coins that need to be inserted into coin mechanism 1 to reach the bonus credit level 3. This setting is only active if P03-3 and P03-4 are active.
- **3 - 6 = Coin 1, Level 3, Number of Bonus Credits** (Default Off) (Adjustable Off, 1 - 99)
This sets the number of bonus credits that are given when credit level 3 is reached. This is the number of bonus credits given, on top of what has been paid for. This setting is only active if P03-3 and P03-4 are active.
- **4 – P06-6**
These settings represent the same settings as P01 – P03 – 6, but for coin mech 2.
- **7 = Common Coin** (Default Off) (Adjustable On or Off)
This is the setting for common coin. If the setting is ON, coin 1 and coin 2 contribute to the same coin pool. If the setting is off, they are counted separately.
- **8 = Attract Sound** (Default Off) (Adjustable Off, 1 minute, 2m, 5m, 10m, 20m, 30m)
This setting controls the delay between the attract mode audio loop repeating.
- **9 = Error Message** (Default Display & Audio) (Adjustable Display & Audio, Audio, Display, Off)
This setting controls how the game alerts you of errors. By default, the game will display a visual warning on the credit display and play a voice over. Alerts can be set to voice over only, display only, or off completely.
- **10 = Free Mode** (Default Off) (Adjustable On or Off)
Defines if the machine is running in free play mode or not.
- **11 = Vend Prizes in Free Mode** (Default On) (Adjustable On or Off)
Defines if the game will vend prizes when running in free play mode.
- **12 = Prize Type** (Default Tic) (Adjustable Tic/Coupon)
Setting the prize type to coupons will still pay out tickets. For every two coupons won, one ticket will be paid out.
- **13 = Number of Mercy Prizes** (Default Off) (Adjustable Off, 1 -20)
Sets the number of prizes paid out for a mercy prize.
- **14 = Mercy Payout Time** (Default Before) (Adjustable Before, After)
Sets when the mercy prize pays out. Either before a game begins, or after a game has ended.
- **15 = Minor Prize** (Default 30) (Adjustable Off, 1-100)
Set if the minor prize is enabled, and how many prizes the game will pay out on a minor win.
- **16 = All Reels Running in Gameplay** (Default On) (Adjustable On or Off)
If set to on, all reels will run simultaneously during gameplay. If set to off, only the active reel will spin.

- **17= Reel Timeout** (Default 30) (Adjustable 30, 60 seconds)
Set the number of seconds the game will wait for player input before timing out.
- **18 = Call Attendant on Jackpot** (Default Off) (Adjustable On or Off)
Sets if the game will prompt the player to call an attendant if the jackpot is won. Setting this is on will stop the game paying out a prize on a jackpot win.
- **19 = Current Jackpot Payout** (Default *) (Adjustable 1 - 9999)
Change the value of the current jackpot payout.
*The value of P22 will represent whatever the current jackpot payout is, displayed on the header.
- **20 =Difficulty** (Default 50) (Adjustable 1-50)
The average number of games played for every major prize won.
- **21 = Payment Type** (Default On) (Adjustable On or Off)
Sets the payment method. This will change the terminology on the credit display.

AUDITS

1. **Total Coins Mech 1**
The total number of coin mech 1 pulses
2. **Total Coins Mech 2**
The total number of coin mech 2 pulses
3. **Total Service Credits**
The total number of service credits used
4. **Total Games Played**
The total number of games played
5. **Total Mercy Tickets**
The total number of mercy tickets paid out
6. **Total Minor Tickets**
The total number of tickets paid out for the minor prize
7. **Total Major Tickets**
The total number of tickets paid out for the major prize
8. **Average Tickets Per Game**
The average amount of tickets paid out per game
9. **Total Major Wins**
The total number of major prize wins
10. **Total Minor Wins**
The total number of minor prize wins
11. **Total Choose Cont.**
The total number of players who have opted to continue after winning the minor prize
12. **Total Losses**
The total number of players who lost the game
13. **Skill Wins**
The total number of major prizes won by players before the specified difficulty is met
14. **Balance Win**
The number of major skill wins that have been balanced out
15. **Losses at Reel 1**
The total number of players who lost at reel mech 1

- 16. Losses at Reel 2**
The total number of players who lost at reel mech 2
- 17. Losses at Reel 3**
The total number of players who lost at reel mech 3
- 18. Losses at Reel 4**
The total number of players who lost at reel mech 4
- 19. Losses at Reel 5**
The total number of players who lost at reel mech 5
- 20. Losses by Game Timeout**
The total number of players who lost due to the game timing out
- 21. Miss at Reel 1**
The total number of players who stopped on red on reel mech 1
- 22. Miss at Reel 2**
The total number of players who stopped on red on reel mech 2
- 23. Miss at Reel 3**
The total number of players who stopped on red on reel mech 3
- 24. Miss at Reel 4**
The total number of players who stopped on red on reel mech 4
- 25. Miss at Reel 5**
The total number of players who stopped on red on reel mech 5
- 26. Bucket 1**
Manufacturer's audit
- 27. Bucket2**
Manufacturer's audit
- 28. Bucket3**
Manufacturer's audit
- 29. Checksum**
Manufacturer's audit

INPUT AND OUTPUT TESTS

OUTPUT TESTS

1. **Run All Lights**
This test will count from 0 to 9999 on the 7 segment display, and flash all cabinet lighting.
2. **Button Lights**
Turn all the button lamps on and off.
3. **RGB Blue**
Turn all reel lights on and off.
4. **RGB Green**
Turn the green RGB light on and off.
5. **RGB Red**
Turn the red RGB light on and off.
6. **7 Segments**
This test will display 1111 on the 7 segment display.

INPUT TESTS

Each input test will indicate whether the input is currently active or inactive.

1. **Up/Take Button**
2. **Down/Continue Button**
3. **Utility Button**
4. **Stop Button**
5. **Coin 1**
6. **Coin 2**
7. **Ticket Notch 1**
8. **Ticket Notch 2**

RUN TESTS

Each component listed in the run test can be set to running or stopped.

1. **Ticket Mechs**
 1. **Ticket Motor 1**
 2. **Ticket Motor 2**
2. **Reel Mechs**
 1. **Reel mech motor 1**
 2. **Reel mech motor 2**
 3. **Reel mech motor 3**
 4. **Reel mech motor 4**
 5. **Reel mech motor 5**

HISTORY

MAJOR WIN HISTORY

The Major Win History menu stores information on the last five major wins. The entries are stored in the below format.

When viewing a major win history entry, the reel mech will automatically move to display the position that the game ended on.

MAJOR WIN HIST 2
SKILL

- **Major Win Hist (1-5)**
The entry number, ranging from the most recent game (1) to the 5th most recent game (5).
- **Win Type: Skill / Normal**
Indicates if the win was a skill win or a normal win.

GAME HISTORY

The Game History menu stores information on the last five game plays. The entries are stored in the below format.

GAME HISTORY 1
LOSE R_5

- **Game History (1 – 5)**
The entry number, ranging from the most recent game (1) to the 5th most recent game (5).
- **End State: LOSE / MIN / MJR / SKIL / ERR**
The game result; lose, minor or major win, major skill win or an error ending the game.
- **Reel Mech Number: R_1 – 5**
The reel mech number that the game ended on.

CALIBRATION

The calibration function can be used to ensure that the game has recorded the win and lose positions of each reel mech correctly.

The Vault will always come calibrated.

NOTE

Recalibrating a reel mech needs a lot of attention to detail and is time consuming.
Recalibrating a reel mech is not recommended unless it is absolutely necessary.

Each reel (REEL 1 to REEL 5) has a red section (lose) and a blue section (win).

Each section covers a range of stepper positions. BEG: ## indicates the starting stepper position, and END: ## indicates the last stepper position that the section covers.

Below is example of how reels 1 and 5 could be calibrated.

Reel number	Win Area	Begin Position	Sticker End Position
REEL 1	Blue	50	90
REEL 5	Blue	10	20

To view the start beginning and end position of a sticker on a reel, follow the steps below:



CHANGE STICKER RANGE

To change the range of a sticker on a reel, follow the instructions above until the LCD displays the information shown below.

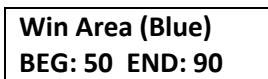

To change the BEG position, hold the right button for 3 seconds, and LCD will display

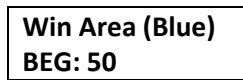

To change the END position, hold the right button for 3 seconds a second time, and the LCD display will change to →

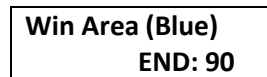

Press the up or down buttons to increment or decrement the BEG or END values.

RESET TO DEFAULT

Hold the utility button for five seconds when the LCD displays the below information to reset all calibration data to default. The game will need to be recalibrated after a reset.

NOTE
 Resetting calibration data back to default is not recommended unless the game is experience operational issues, or LAI Support has advised the action.

ERRORS

Error Code	Name	Cause	Solution
Err1	Ticket error	The game has run out of tickets.	Refill the ticket mechs. When the tickets have been reloaded, the game will automatically vend any owing tickets and clear the error.
Err2	Coin 1 error	The coin sensor has been pressed for a long period of time.	Release the coin sensor to clear the error.
Err3	Coin 2 error	The coin sensor has been pressed for a long period of time.	Release the coin sensor to clear the error.
Err4	Stop button error	The stop button has been pressed for a long period of time.	Release the stop button to clear the error.
Err5	Utility button error	The utility button has been pressed for a long period of time.	Release the utility button to clear the error.
Err6	Up/take win button error	The up or take win button has been pressed for a long period of time.	Release the up and take win button to clear the error.
Err7	Down/continue button error	The down or continue button has been pressed for a long period of time.	Release the down and continue button to clear the error.
Err8	Left button error	The left button has been pressed for a long period of time.	Release the left button to clear the error.
Err9	Right button error	The right button has been pressed for a long period of time.	Release the right button to clear the error.
Err10	ERROR EEPROM PSET EEPROM game settings error	The firmware has failed to load data on the game settings. Default settings are now being used.	Check that the i2c eeprom chip is firmly seated on the PCB. Exit and re-enter the operator menu, or hold down the right / test button for 3 seconds while in the Error menu.
Err11	ERROR EEP AUDIT R EEPROM resettable audits error	The firmware has failed to load data on the resettable audits	Hold down the right / test button for 3 seconds while in the Error menu.
Err12	ERROR EEP AUDIT UR EEPROM un-resettable audits error	The firmware has failed to load data on the un-resettable audits	
Err13	EEPROM new jersey error *for new jersey firmware only	The firmware has failed to load New Jersey specific settings.	

Err14	Reel mech calibration data error	The current calibration data stored in the eeprom is invalid.	Recalibrate the reel mech. Please note that recalibrating a reel mech needs a lot of attention to detail and is time consuming. Recalibrating a reel mech is not recommended unless it is absolutely necessary.
Err15	PCB communication error	The master PCB is failing to communicate with the slave PCB	Make sure the serial cable is securely connected and both PCBs are operating correctly
Err16	Reel mech 1 error / home sensor error	The reel mech 1 sensor is undetected.	Make sure the reel mech sensor is unobstructed, the cable connecting it to the PCB is connected correctly and in good condition. Make sure FB201 is functioning correctly and then reset the machine.
Err17	Reel mech 2 error / home sensor error	The reel mech 2 sensor is undetected.	
Err18	Reel mech 3 error / home sensor error	The reel mech 3 sensor is undetected.	
Err19	Reel mech 4 error / home sensor error	The reel mech 4 sensor is undetected.	
Err20	Reel mech 5 error / home sensor error	The reel mech 5 sensor is undetected.	

SECTION A: SERVICE INSTRUCTIONS

NOTE
Be sure to read the following carefully before servicing the machine.

LOCATING AND ACCESSING PARTS

The following pictures identify the location of the main serviceable items.

CABINET FRONT

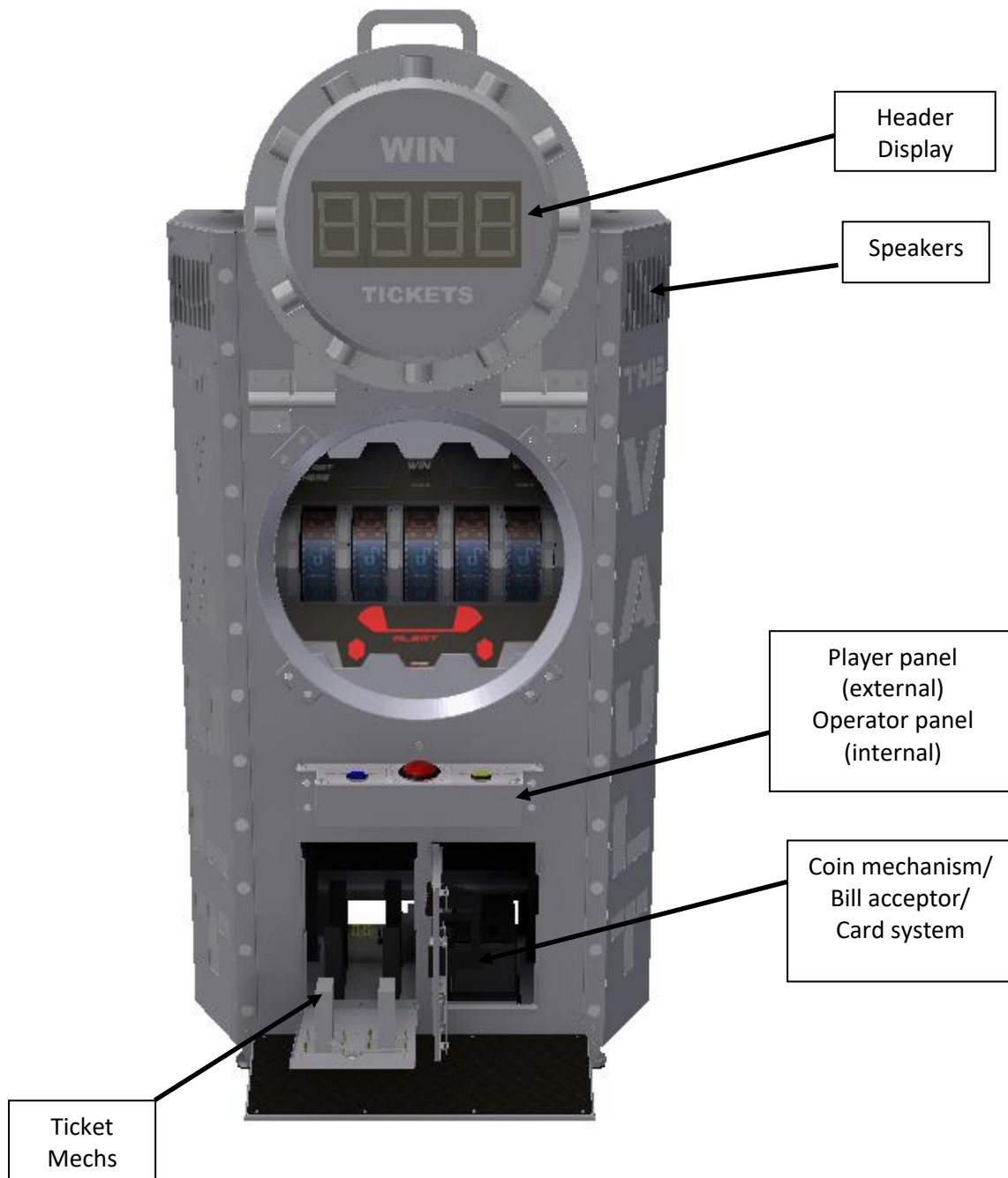

CABINET REAR

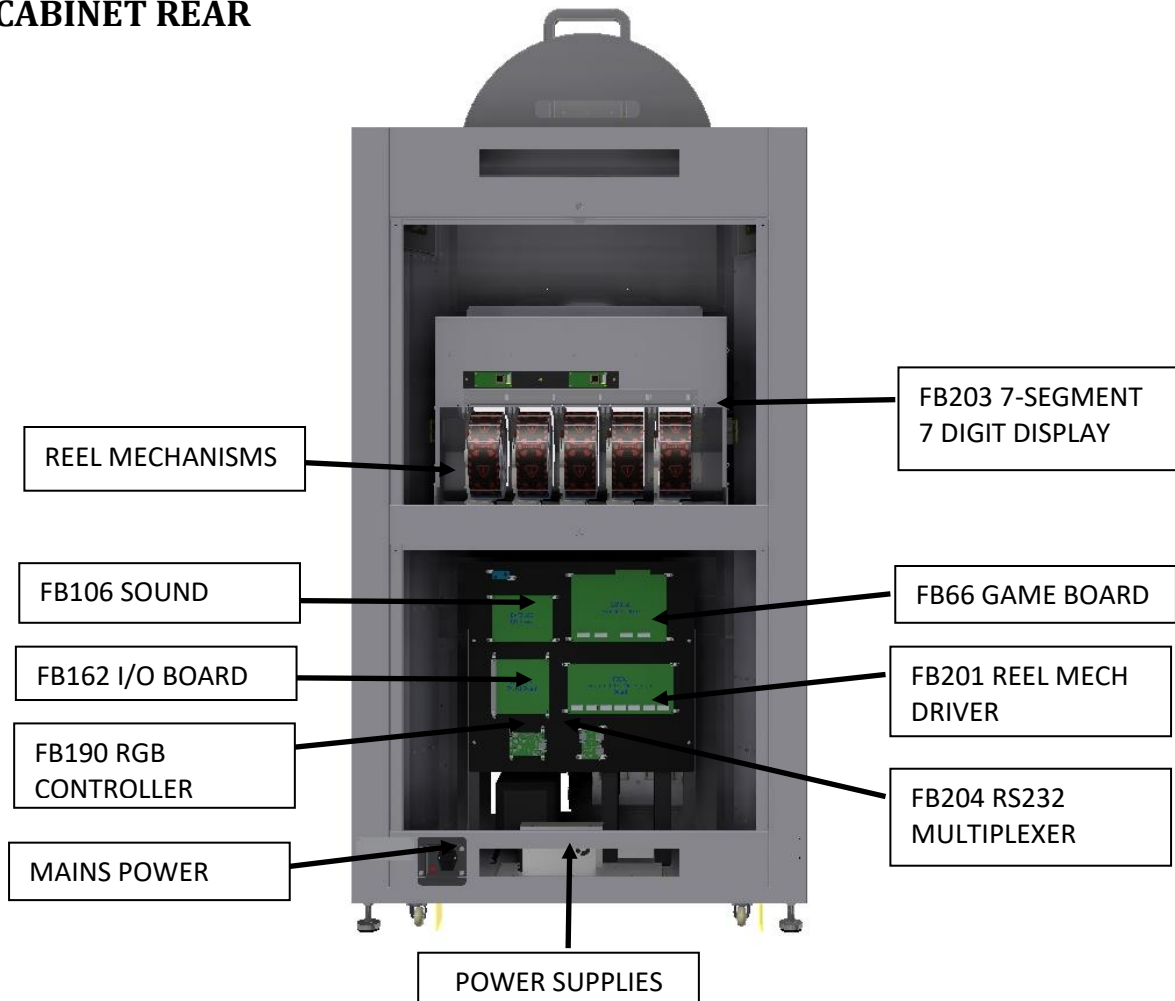

OPERATOR PANEL - SERVICE CONTROLS

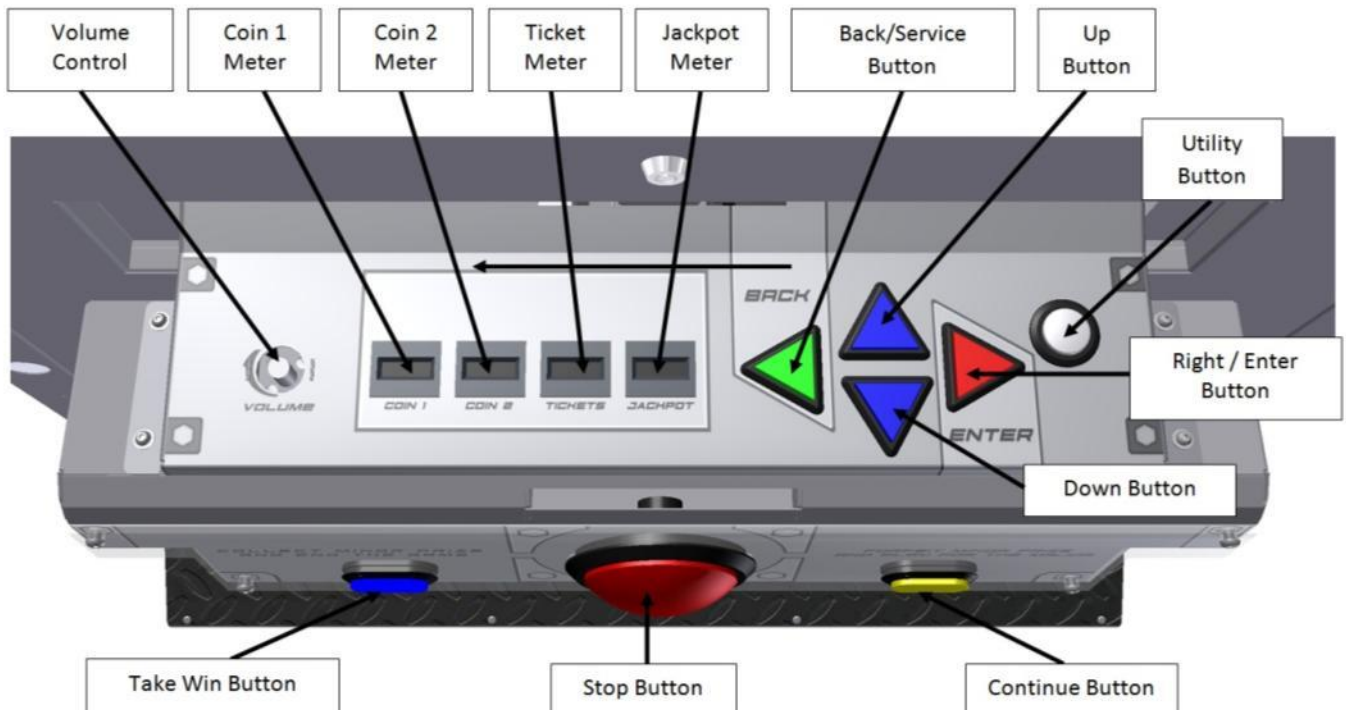

PARTS DESCRIPTION

HEADER DISPLAY

The header is illuminated by RGB LED lighting, under control of the FB190 RGB Controller. The current jackpot is displayed on the FB62 7-segment display.

SPEAKERS

Two speakers are wired directly to the left and right channels of the FB106 sound PCB.

COUNTERS

Counters will increment for each coin inserted and each ticket paid out. Counters are under firmware control and are not directly connected to the mechanisms.

BUTTONS

Press the green SERVICE/BACK button to issue a service credit from attract mode.

Press the red TEST/ENTER button to enter the operator menu from attract mode.

When in the operator menu, use all four buttons to navigate through the menu.

VOLUME KNOB

Use to adjust the speaker's sound level.

COIN MECHANISM/BILL ACCEPTOR/CARD SYSTEM

Credits can be inserted via a coin mech, bill acceptor and/or card system connection. All interfaces are located inside the front coin door.

TICKET MECHS

Tickets won are paid out equally from two ticket mechs. If one mech is empty or jammed, then all tickets are paid out on the remaining mech. A ticket error will only occur when both ticket mechs are empty or jammed.

REEL MECHS

Five Reel mechanisms are independently driven during attract and game modes by the FB201 and FB66.

POWER INLET/MAINS SWITCH

The power inlet is a standard IEC inlet socket with a mains power switch, located at the rear of the machine. There is a main power fuse internal in this IEC socket. The fuse should be a M205, 250VAC, 3A.

WARNING

ALWAYS turn **OFF** mains power and unplug the game before replacing any fuses, and **ALWAYS** use the correct rated fuse.

POWER SUPPLIES

The Vault has two power supplies – 12VDC SP-320-12 and 24VDC SP-320-24. Both are located at the rear bottom of the cabinet and are accessible via the rear service panel of the machine. Power supplies are universal input models which can handle AC input from 100-240VAC at 50/60Hz. An adjustment screw is available for fine-tuning the output voltage. 12VDC is used for the whole game. 12VDC and 24VDC are both used for the reel mechanisms via the FB201 PCB.

LAMPS

WARNING

Always turn **OFF** mains power and unplug the game, before replacing any lamps.
Always replace the lamps with the same or equivalent size, wattage and voltage.

All button lamps are 12VDC T10 LED or equivalent. All remaining lighting is RGB LED strip controlled by the FB190 RGB Controller.

MAINTENANCE

EXTERIOR

- Regularly dust and clean the external cabinet areas as required, using a soft water-damp cloth and mild soap.
- Check for blown bulbs and replace as required. Check all LED strips are functioning and repair as required.
- Check the monitor image is clear.
- Wipe the monitor clean with a soft damp cloth.

INTERIOR

- Regularly dust and vacuum the interior of the cabinet, taking care to remove any objects that may have fallen.
- Check and tighten all fixing hardware and fasteners as required.

WARNING

Always turn **OFF** mains power and unplug the game before cleaning the interior of the machine.

SECTION B: TECHNICAL DETAILS



It is advised that anybody using SECTION B for repairing or modifying any of the components of the game should be a qualified technician, having at least a basic knowledge of digital components, integrated circuits and electricity.

POWER SUPPLY

The universal AC input power supplies generates 12VDC and 24VDC for the entire machine. The green LED indicates powered operation.

The power supply output voltage should be 12VDC. It can be adjusted when necessary by turning the blue adjustment trimpot with a small Philips screwdriver.

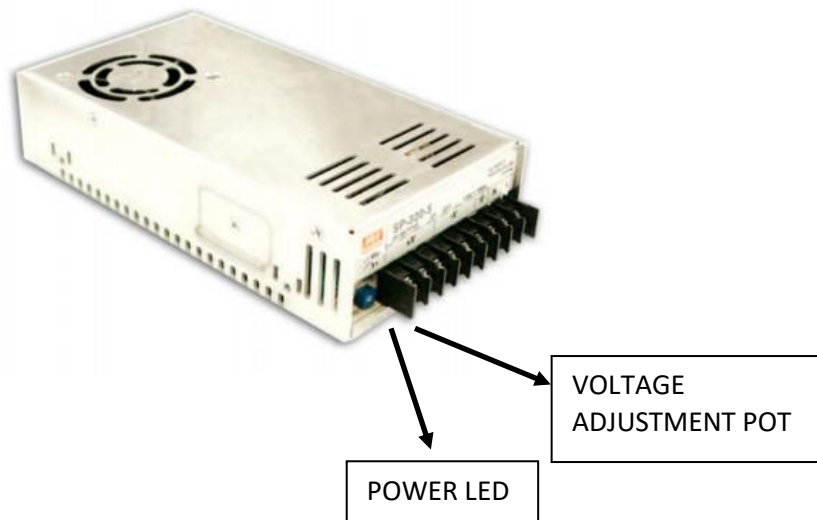

COIN OPTIONS REFERENCE GUIDE

By default, the coin door contains a micro switch connected to the COIN2 input for crediting the machine.

A 9 way Molex connector has been installed on the coin door which can be optionally used to make adaptors for most electronic coin systems and comparators.

The following picture illustrates the connector pinout.

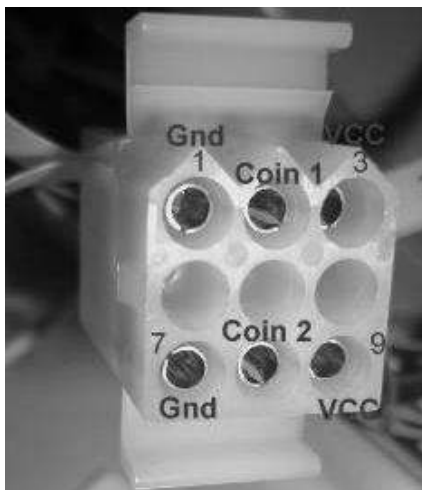

Shell part number: Molex 03-09-1092

Pins: Molex 02-09-1119 (loose)
Molex 02-09-1117 (chain)

PIN1 = GND
PIN2 = COIN1 input
PIN3 = 12VDC
PIN7 = GND
PIN8 = COIN2 input
PIN9 = 12VDC

Contact your nearest LAI Games distributor for harnessing to suit different coin comparators and bill acceptors.

UNIVERSAL CARD LINK CONNECTION

A 9 pin Universal Card Link connector exists on the operator panel inside the coin door.

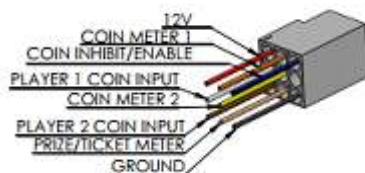

Mating shell part number: Molex 9-pin housing: 03-09-2092

Pins part number: Wire Gauge and Terminals: 02-09-2103 (14-20 gauge wire) or 02-09-2118 (18-22 gauge wire)

Pin 1. +12v- Supply to Card System.

Pin 2. Coin 1- input to the game PCB.

Pin 3. Coin 2- input to the game PCB.

Pin 4. Coin meter 1- is connected to the coin meter 1 output from the game PCB and can be used by card systems for monitoring purposes.

Pin 5. Coin meter 2- is connected to the coin meter 2 outputs from the game PCB and can be used by card systems for monitoring purposes.

Pin 6. Ticket Meter- is connected to the Ticket 1 Meter output from the game PCB and can be used by card systems for monitoring purposes.

Pin 7. Empty

Pin 8. Empty

Pin 9. Ground- is connected to the common Ground connection, the same ground as the Game PCB.

TICKET MECHANISMS

2 x ticket mechs can be fitted inside the ticket doors. Connections are available through a standard 4 way Molex receptacle. Deltronic DL-1275 mechs are installed by default.

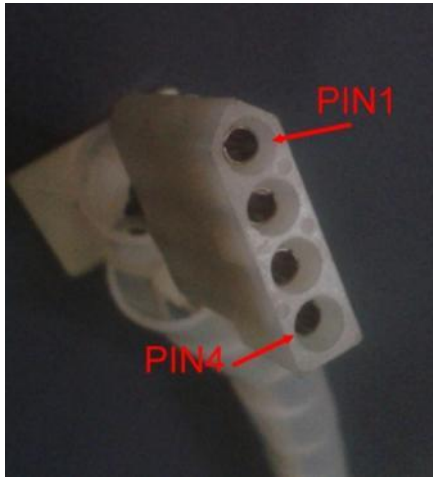

Shell part number: Molex 03-09-1042

Pins: Molex 02-09-1119 (loose)
Molex 02-09-1117 (chain)

PIN1 = NOTCH
PIN2 = GND
PIN3 = DRIVE
PIN7 = 12VDC

WIRING DIAGRAMS

(Next Page)

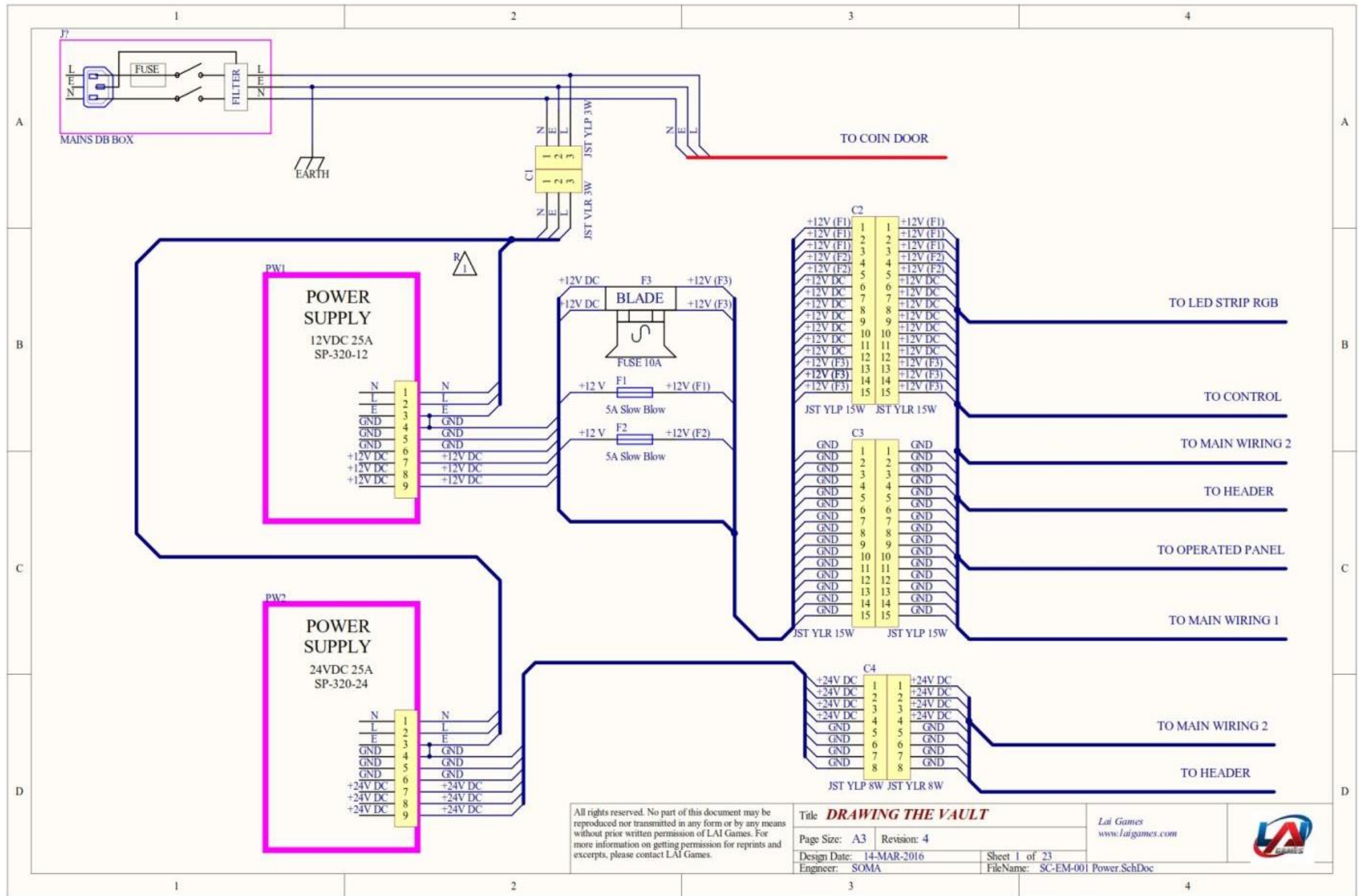

All rights reserved. No part of this document may be reproduced nor transmitted in any form or by any means without prior written permission of LAI Games. For more information on getting permission for reprints and excerpts, please contact LAI Games.

Title DRAWING THE VAULT	
Page Size: A3	Revision: 4
Design Date: 14-MAR-2016	Sheet 1 of 23
Engineer: SOMA	FileName: SC-EM-001 Power.SchDoc

Lai Games
www.laigames.com



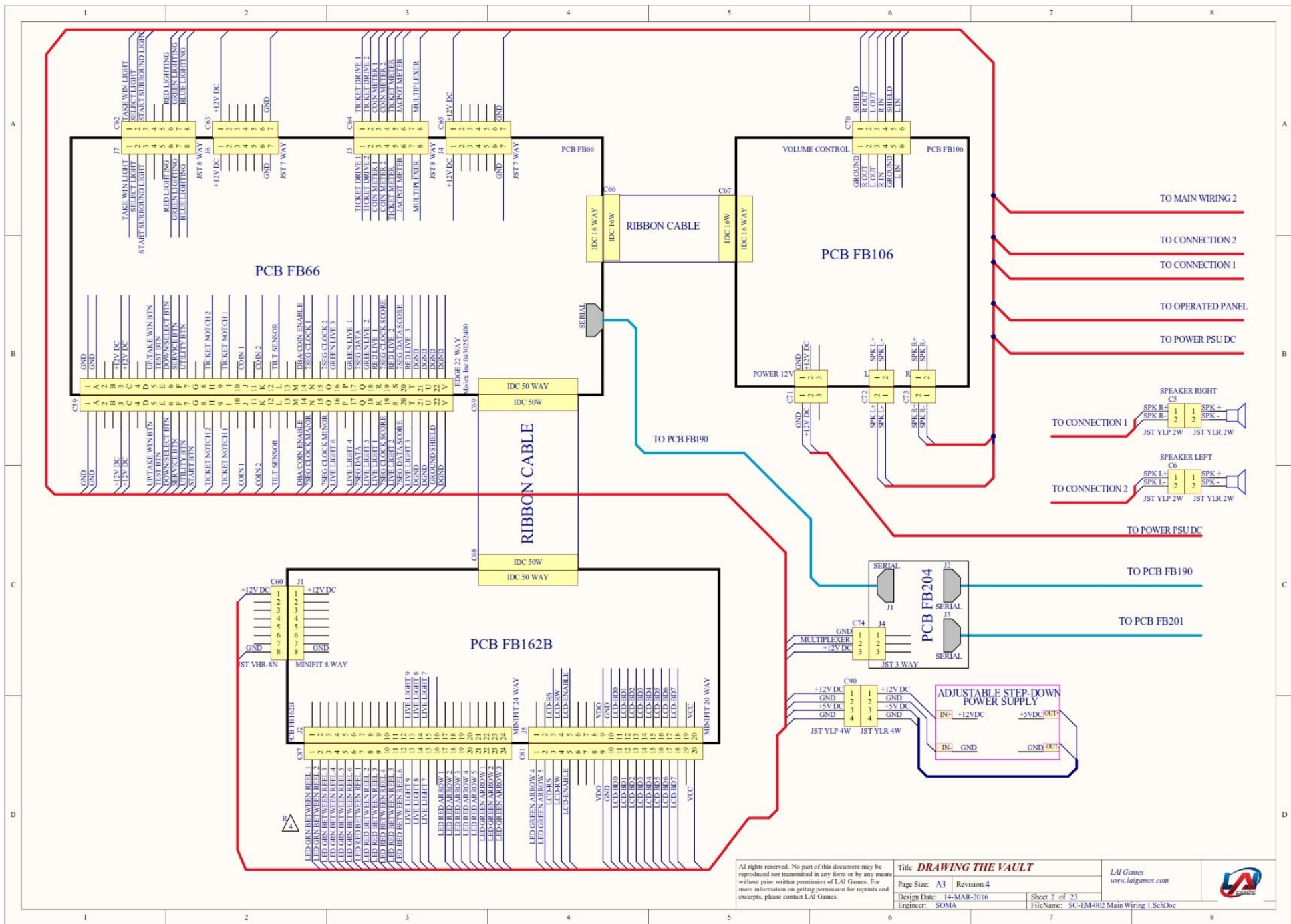

All rights reserved. No part of this document may be reproduced nor transmitted in any form or by any means without prior written permission of LAI Games. For more information on getting permission for reprints and excerpts, please contact LAI Games.

Title DRAWING THE VAULT		LAI Games www.laigames.com	
Page Size: A3	Revision: 4		
Design Date: 14-MAR-2016	Sheet 2 of 23		
Engineer: SOMA	FileName: SC-EM-002 Main Wiring 1.SchDoc		

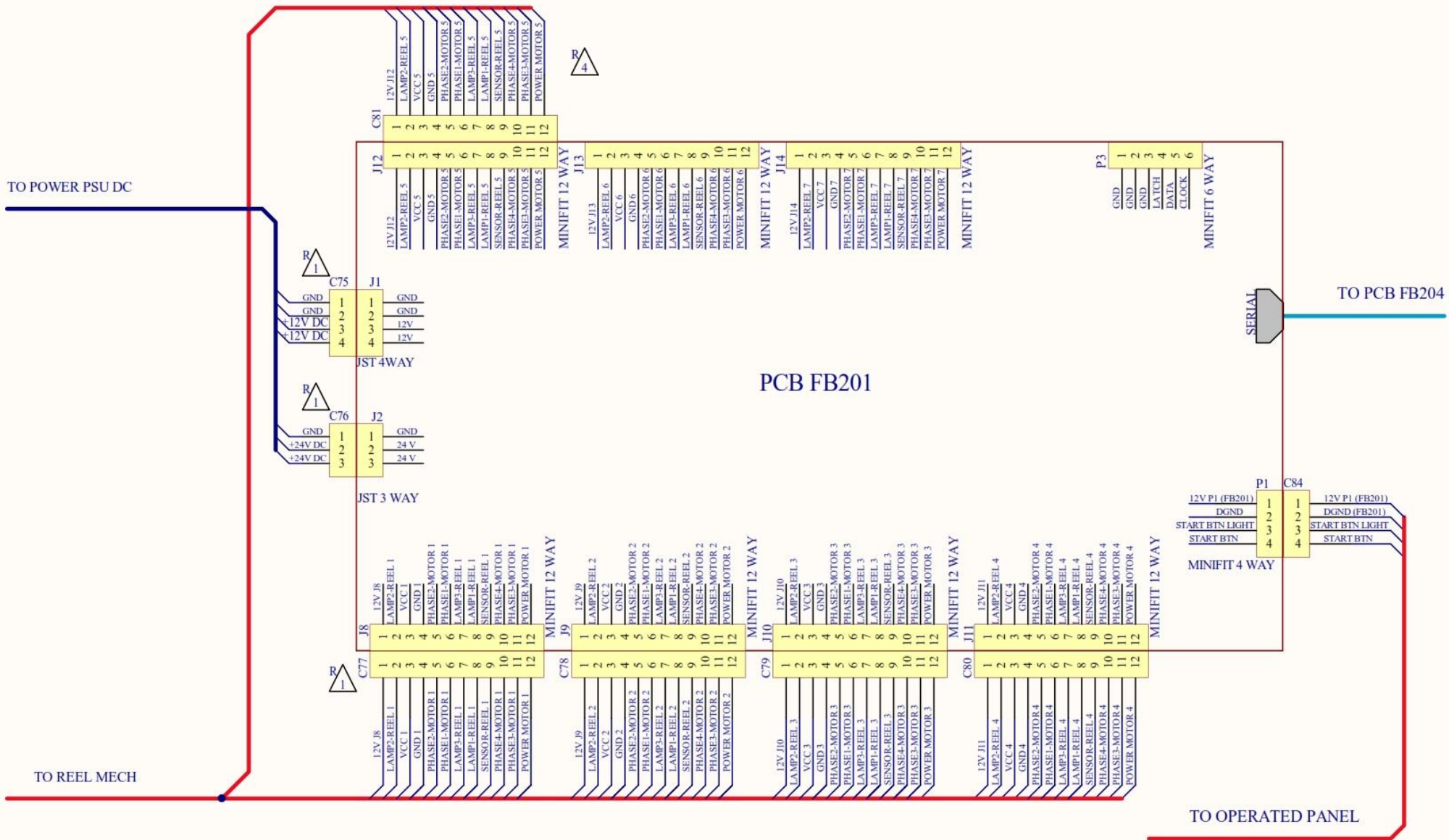

PCB FB201

All rights reserved. No part of this document may be reproduced nor transmitted in any form or by any means without prior written permission of LAI Games. For more information on getting permission for reprints and excerpts, please contact LAI Games.

Title DRAWING THE VAULT	
Page Size: A3	Revision: 4
Design Date: 14-MAR-2016	Sheet 3 of 23
Engineer: SOMA	FileName: SC-EM-003 Main Wiring 2.SchDoc

LAI Games
www.laigames.com



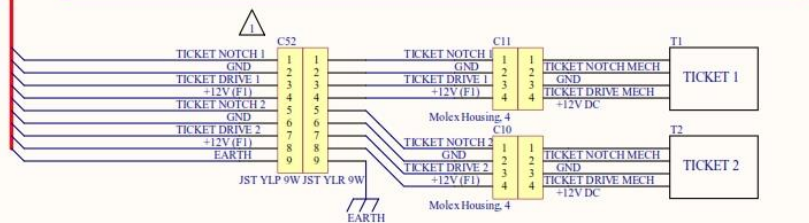
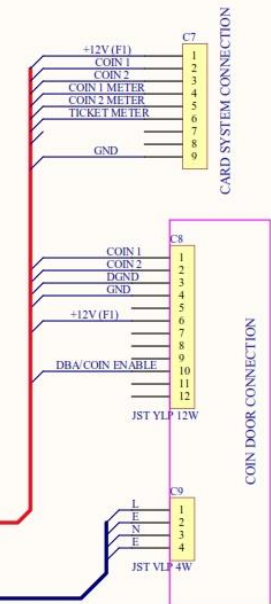
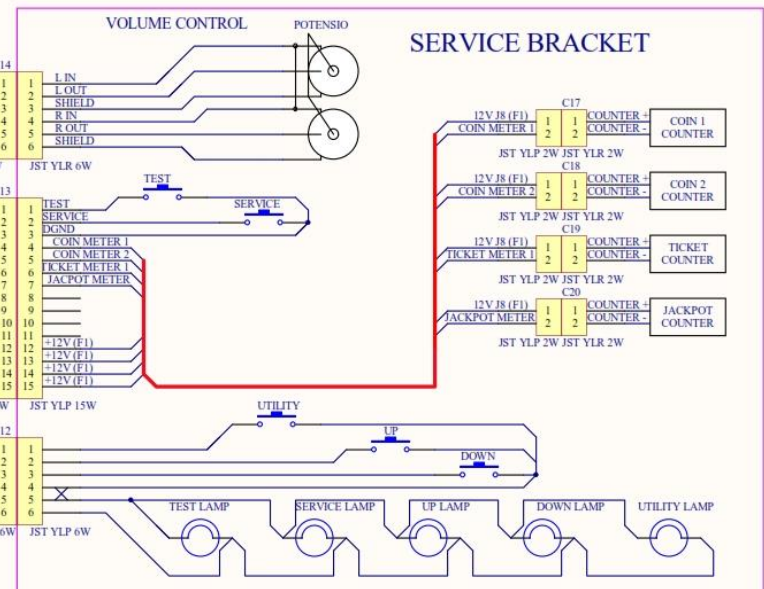
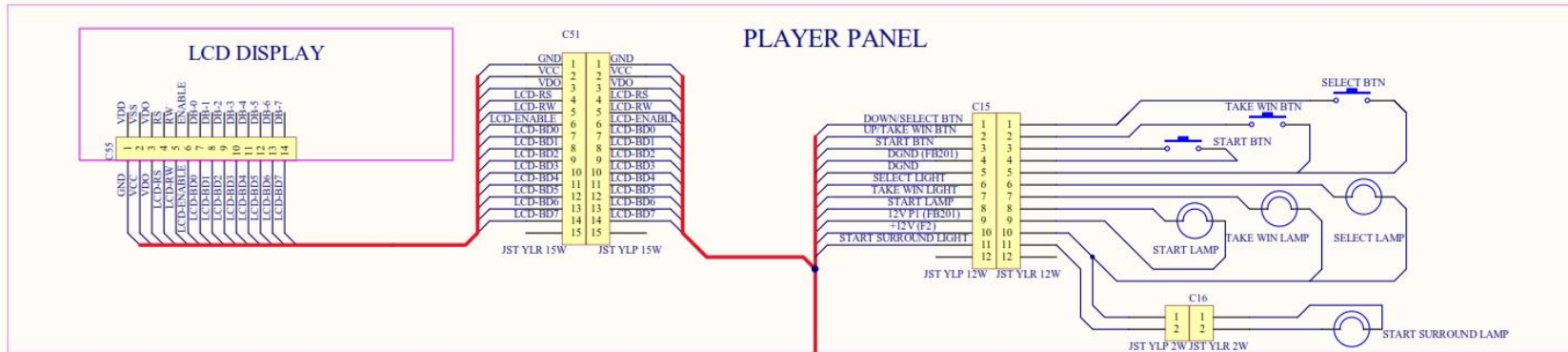

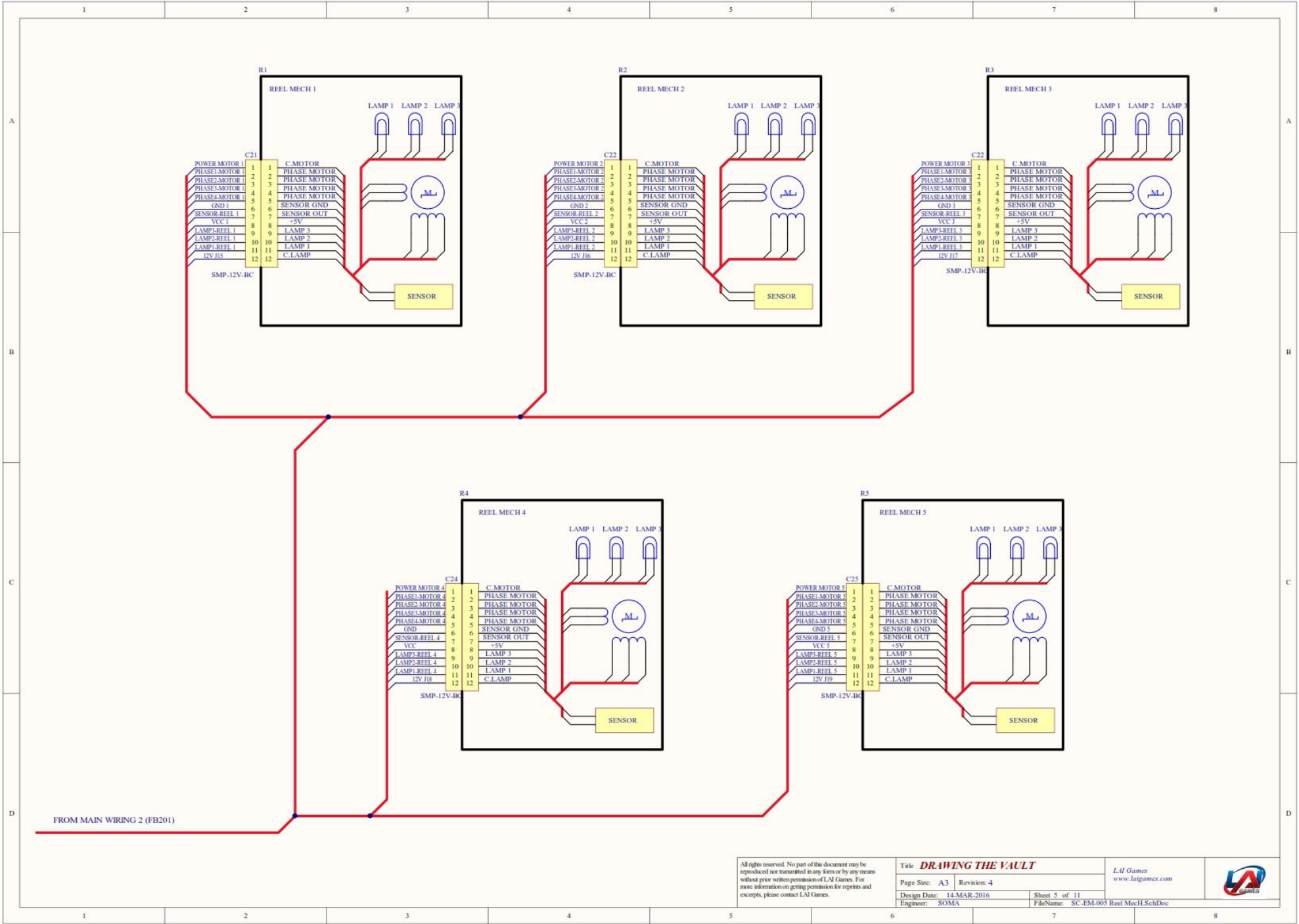

All rights reserved. No part of this document may be reproduced nor transmitted in any form or by any means without prior written permission of LAI Games. For more information on getting permission for reprints and excerpts, please contact LAI Games.

Title: DRAWING THE VAULT	
Page Size: A3	Revision: 4
Design Date: 14-MAR-2016	Sheet 5 of 11
Engineer: SOMA	FileName: SC-EM-005 Reel Mech.SchDoc

LAI Games
www.laigames.com



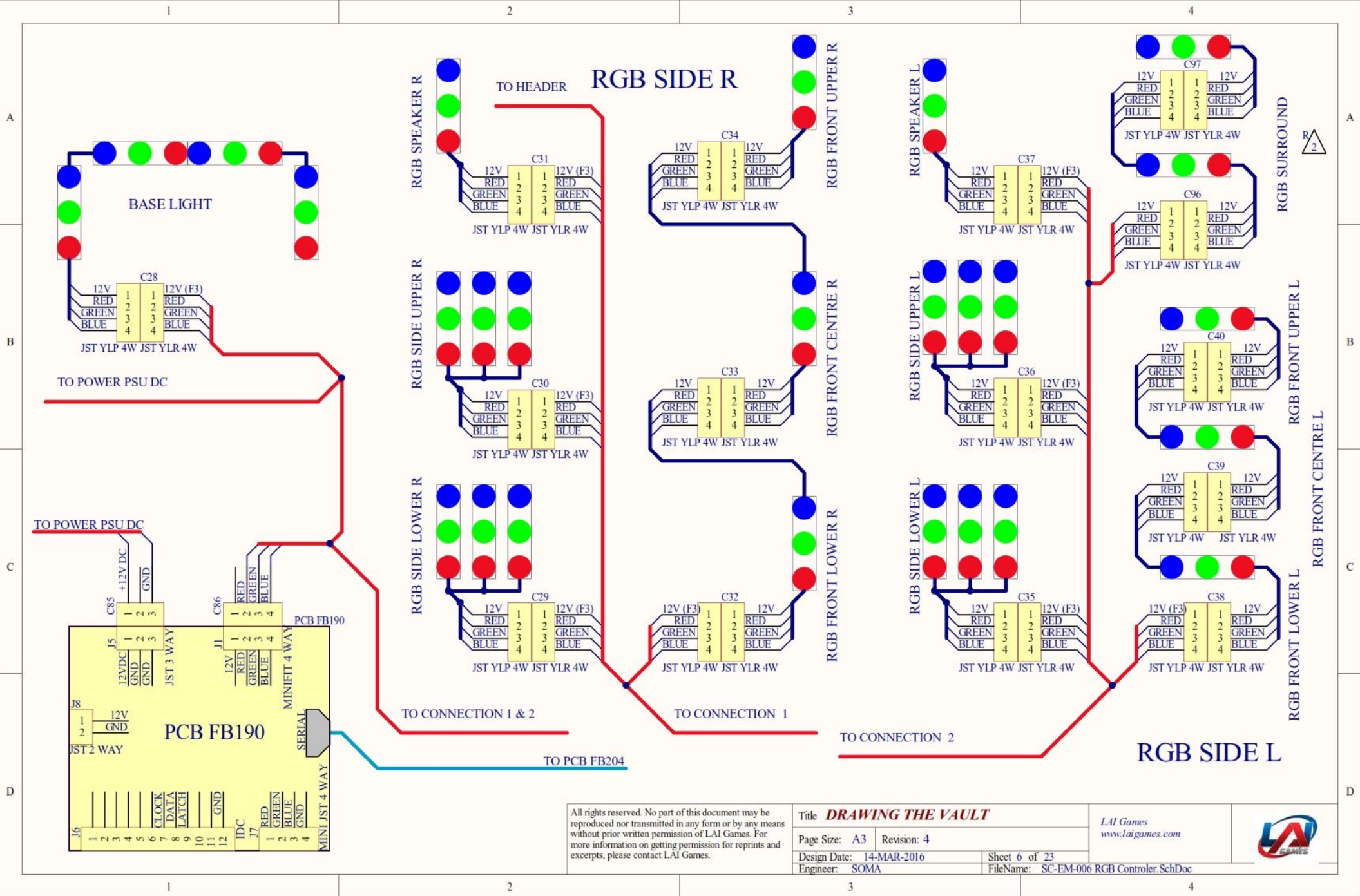

LIGHTING

CONTROL

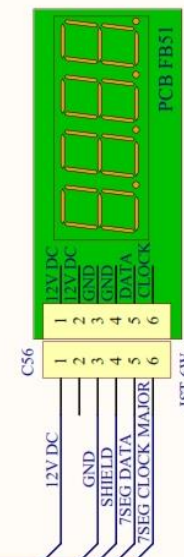
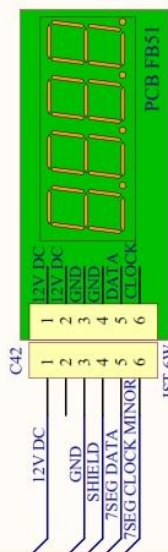
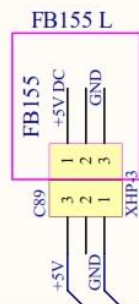
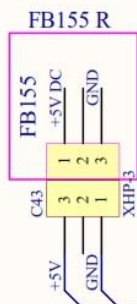
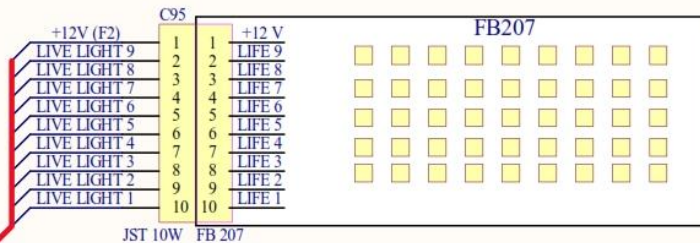
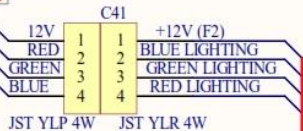
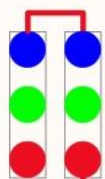

TO CONNECTION MAIN WIRING 1

All rights reserved. No part of this document may be reproduced nor transmitted in any form or by any means without prior written permission of LAI Games. For more information on getting permission for reprints and excerpts, please contact LAI Games.

Title **DRAWING THE VAULT**

Page Size: A3 Revision: 4

Design Date: 14-MAR-2016

Engineer: SOMA

Sheet 7 of 23

FileName: SC-EM-007 Control.SchDoc

LAI Games
www.laigames.com



COIN DOOR STANDARD

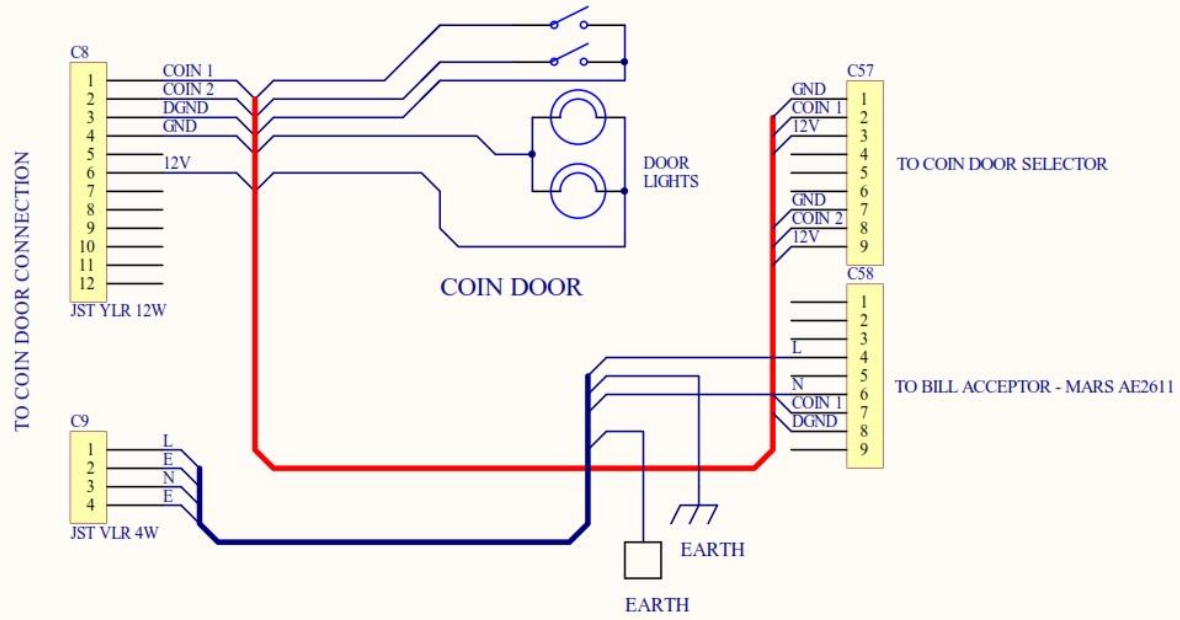

All rights reserved. No part of this document may be reproduced nor transmitted in any form or by any means without prior written permission of LAI Games. For more information on getting permission for reprints and excerpts, please contact LAI Games.

Title **DRAWING THE VAULT**

LAI Games
www.laigames.com

Page Size: A3 Revision: 4

Design Date: 14-MAR-2016

Sheet 8 of 23

Engineer: SOMA

FileName: SC-EM-008 Coin Door Standard.SchDoc



WHEEL LIGHT



R2
LED STRIP RGB

WIN LIGHT



YJ-MK-F2BY35x36-6W

HEADER

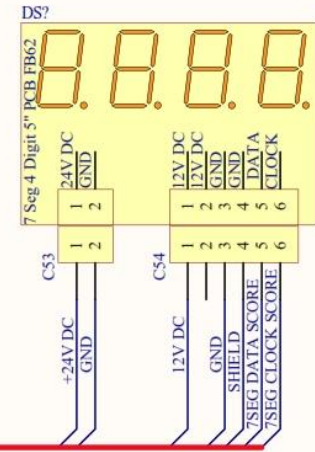
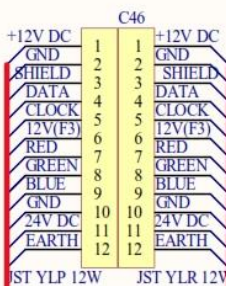
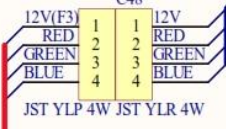
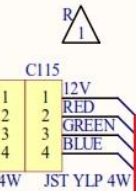

TICKETS LIGHT



YJ-MK-F2BY35x36-6W

TO CONNECTION MAIN WIRING 1

All rights reserved. No part of this document may be reproduced nor transmitted in any form or by any means without prior written permission of LAI Games. For more information on getting permission for reprints and excerpts, please contact LAI Games.

Title **DRAWING THE VAULT**

LAI Games
www.laigames.com

Page Size: A3 Revision: 4

Design Date: 14-MAR-2016
Engineer: SOMA

Sheet 9 of 23
FileName: SC-EM-009 Header.SchDoc



OPTIONAL DBA ENABLE MARS BILL ACCEPTOR (AE-2654-U5)

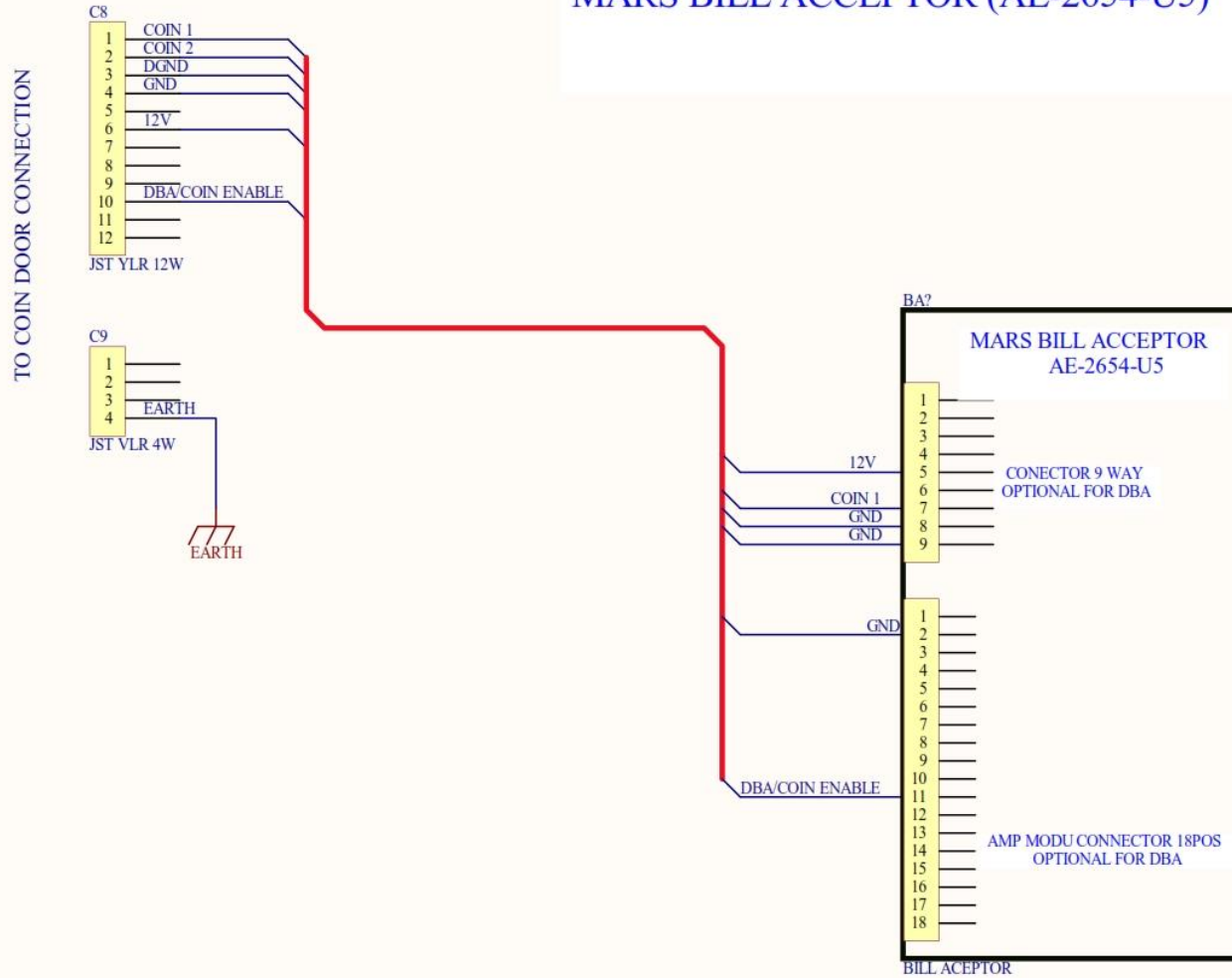

All rights reserved. No part of this document may be reproduced nor transmitted in any form or by any means without prior written permission of LAI Games. For more information on getting permission for reprints and excerpts, please contact LAI Games.

Title **DRAWING THE VAULT**

LAI Games
www.laigames.com

Page Size: A3 Revision: 4

4:28:09 PM 14-MAR-2016

Sheet 10 of 23

Engineer: SOMA

FileName: SC-EM-010 Optional DBA Enable.SchDoc



**(OPTIONAL)
WIRING FOR COIN DOOR
WITH IDC NRI G.13**

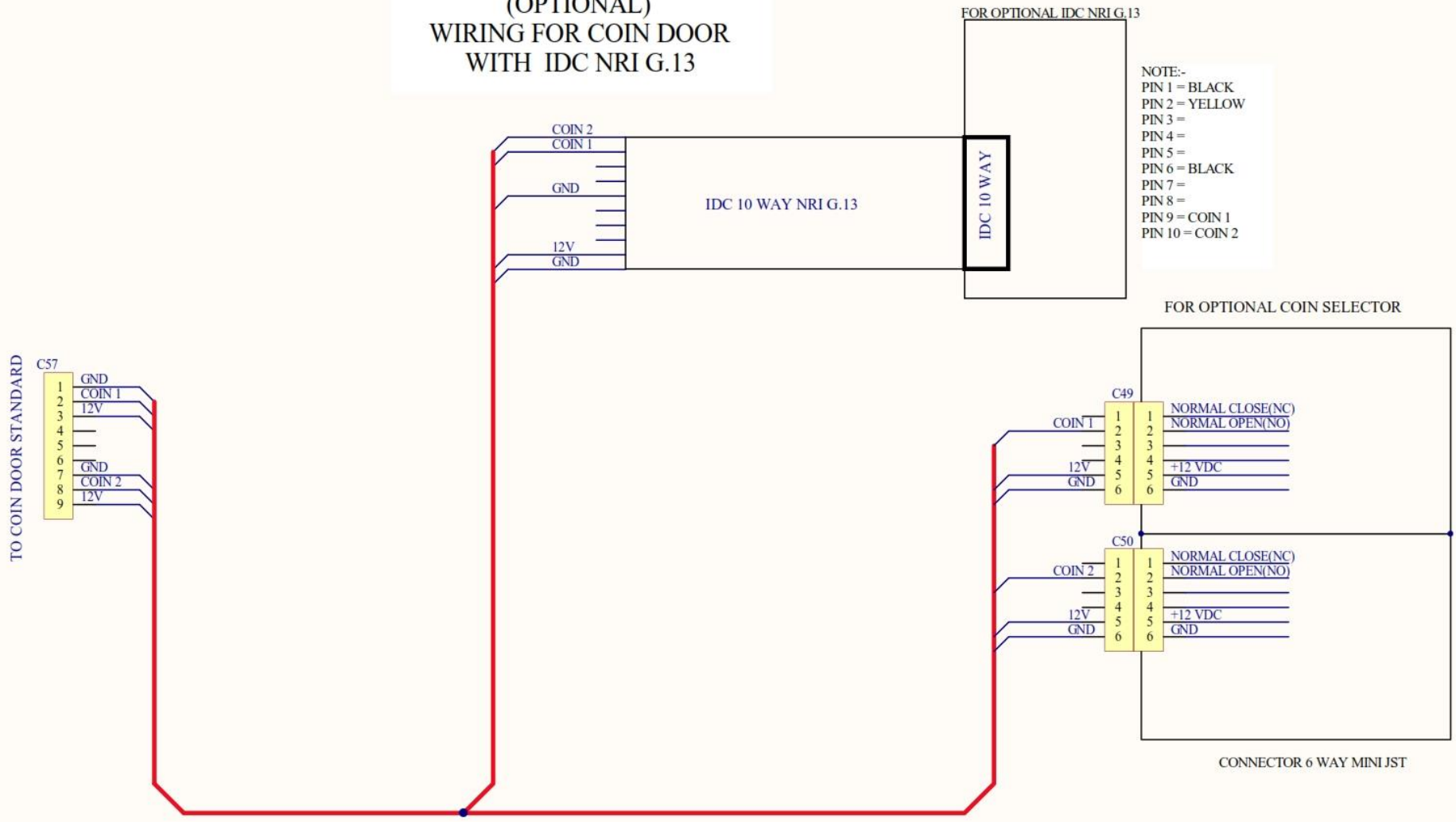

NOTE:-
PIN 1 = BLACK
PIN 2 = YELLOW
PIN 3 =
PIN 4 =
PIN 5 =
PIN 6 = BLACK
PIN 7 =
PIN 8 =
PIN 9 = COIN 1
PIN 10 = COIN 2

All rights reserved. No part of this document may be reproduced nor transmitted in any form or by any means without prior written permission of LAI Games. For more information on getting permission for reprints and excerpts, please contact LAI Games.

Title DRAWING THE VAULT		LAI Games www.laigames.com	
Page Size: A3	Revision: 4		
Design Date: 14-MAR-2016	Sheet 11 of 23		
Engineer: SOMA	FileName: SC-EM-011 Optional Coin Selector.SchDoc		



COIN ENABLE OPTIONAL

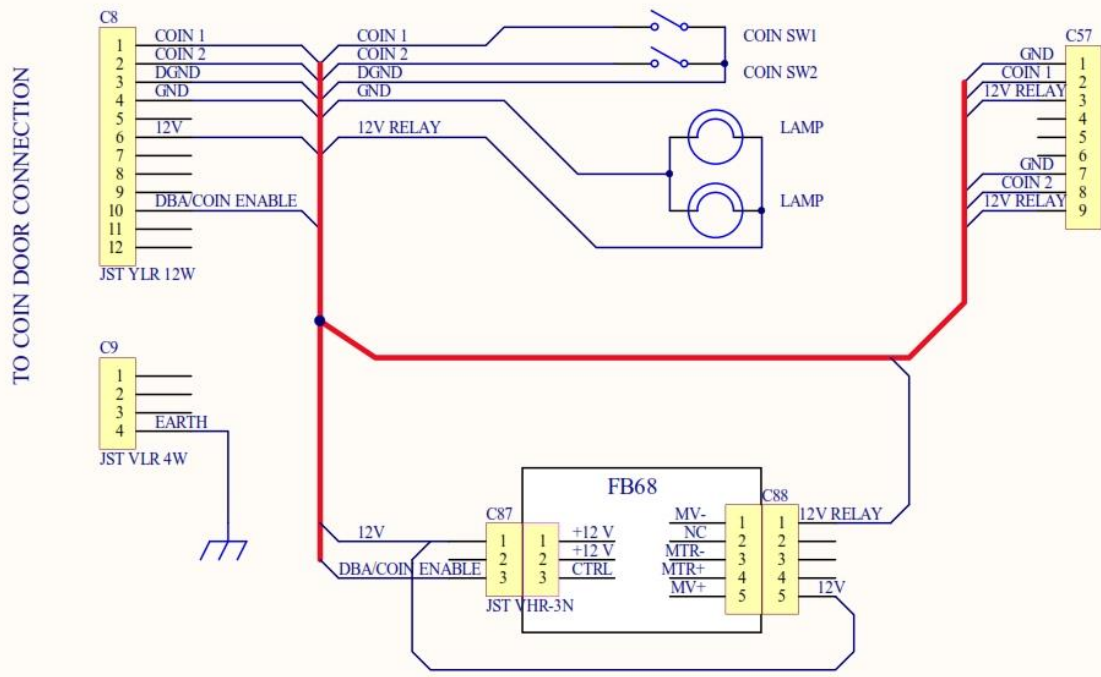

All rights reserved. No part of this document may be reproduced nor transmitted in any form or by any means without prior written permission of LAI Games. For more information on getting permission for reprints and excerpts, please contact LAI Games.

Title **DRAWING THE VAULT**

LAI Games
www.laigames.com

Page Size: A3 Revision: 4

Design Date: 14-MAR-2016 Sheet 12 of 23

Engineer: SOMA

FileName: SC-EM-012 Coin Door Enable.SchDoc



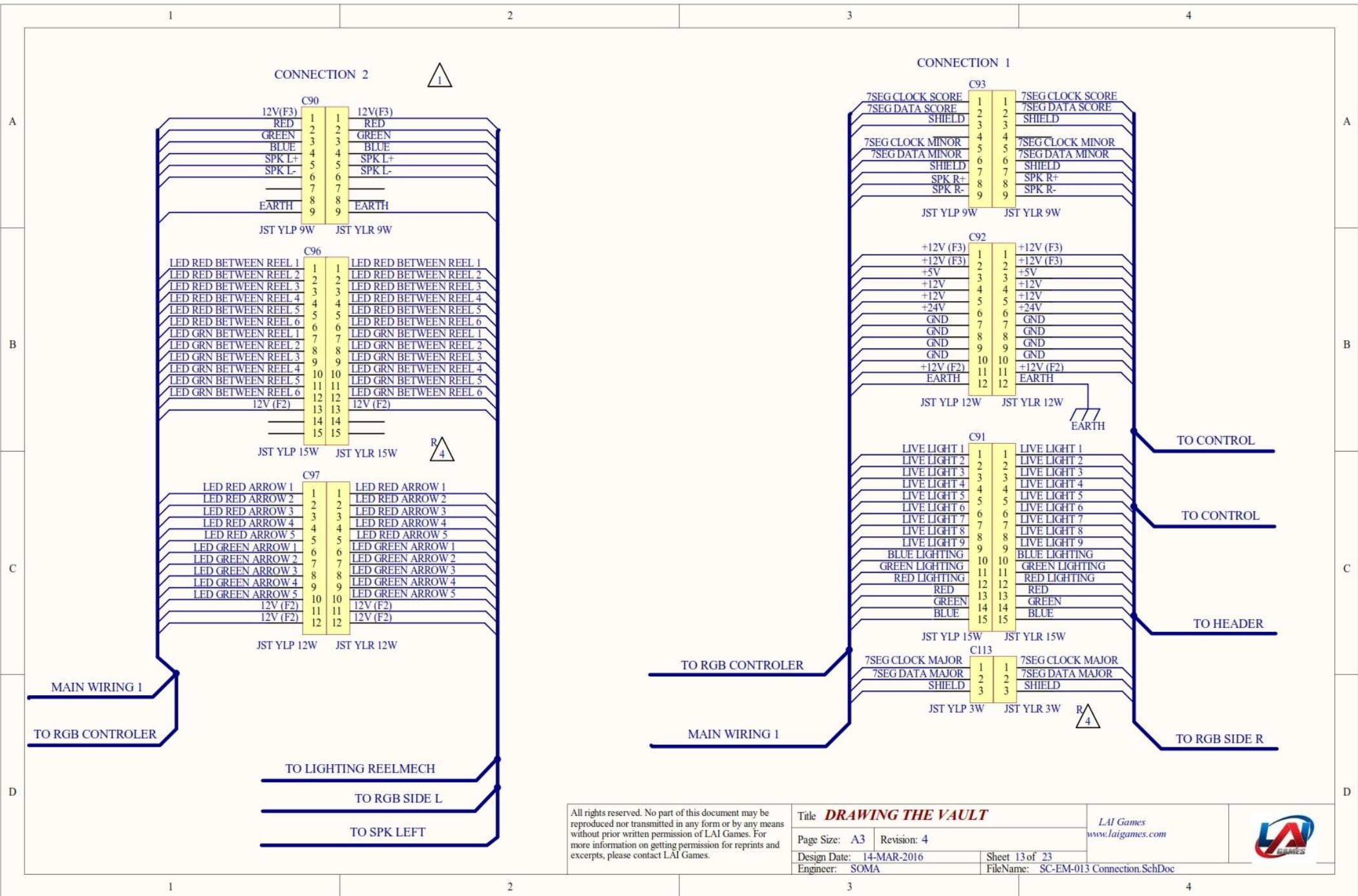

All rights reserved. No part of this document may be reproduced nor transmitted in any form or by any means without prior written permission of LAI Games. For more information on getting permission for reprints and excerpts, please contact LAI Games.

Title **DRAWING THE VAULT**

Page Size: A3 Revision: 4

Design Date: 14-MAR-2016

Engineer: SOMA

Sheet 13 of 23

FileName: SC-EM-013 Connection.SchDoc

LAI Games
www.laigames.com



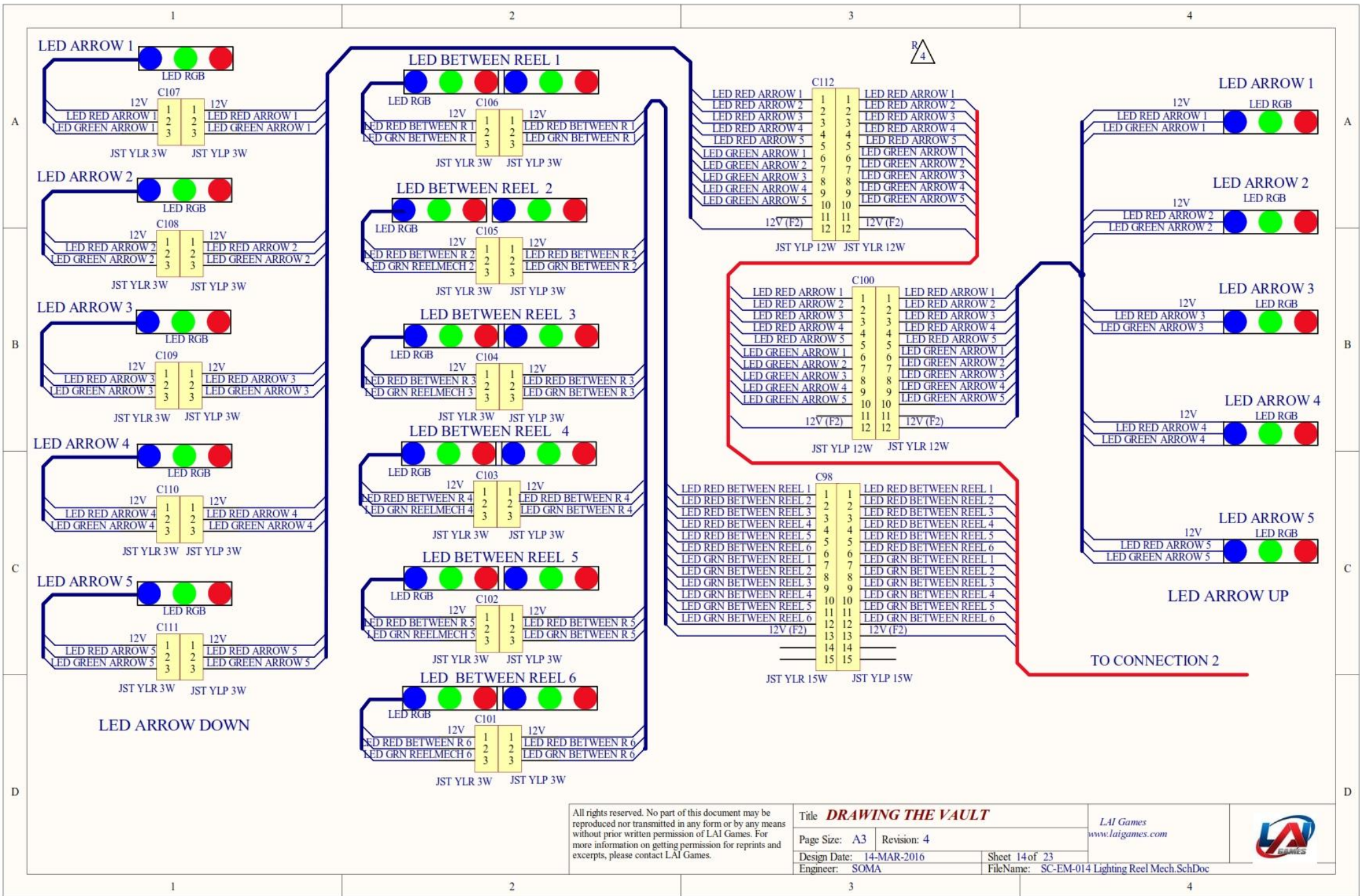

All rights reserved. No part of this document may be reproduced nor transmitted in any form or by any means without prior written permission of LAI Games. For more information on getting permission for reprints and excerpts, please contact LAI Games.

Title **DRAWING THE VAULT**

LAI Games
www.laigames.com

Page Size: A3 Revision: 4

Design Date: 14-MAR-2016

Sheet 14 of 23

Engineer: SOMA

FileName: SC-EM-014 Lighting Reel Mech.SchDoc



MECHANICAL ILLUSTRATIONS

FINAL ASSEMBLY

Parts List			
ITEM	TITLE	PART NUMBER	QTY
1	The Vault - Main Cabinet	SC1-ASSY-02-R1	1
2	The Vault - Front Cabinet	SC1-ASSY-03-R1	1
3	The Vault - Control Panel	SC1-ASSY-05-R1	1
4	The Vault - Reel Mech Box	SC1-ASSY-06-R0	1
5	The Vault - Cash Box	SC1-ASSY-07-R0	1
6	Ticket Holder	SC1-FM-022-R0	2
7	The Vault - Kick Plate	SC1-ASSY-11-R0	1
8	The Vault - PCB Panel	SC1-ASSY-12-R0	1
9	The Vault - Power Supply	SC1-ASSY-13-R0	1
10	The Vault - Back Door	SC1-ASSY-14-R0	2
11	The Vault - Header	SC1-ASSY-04-R1	1

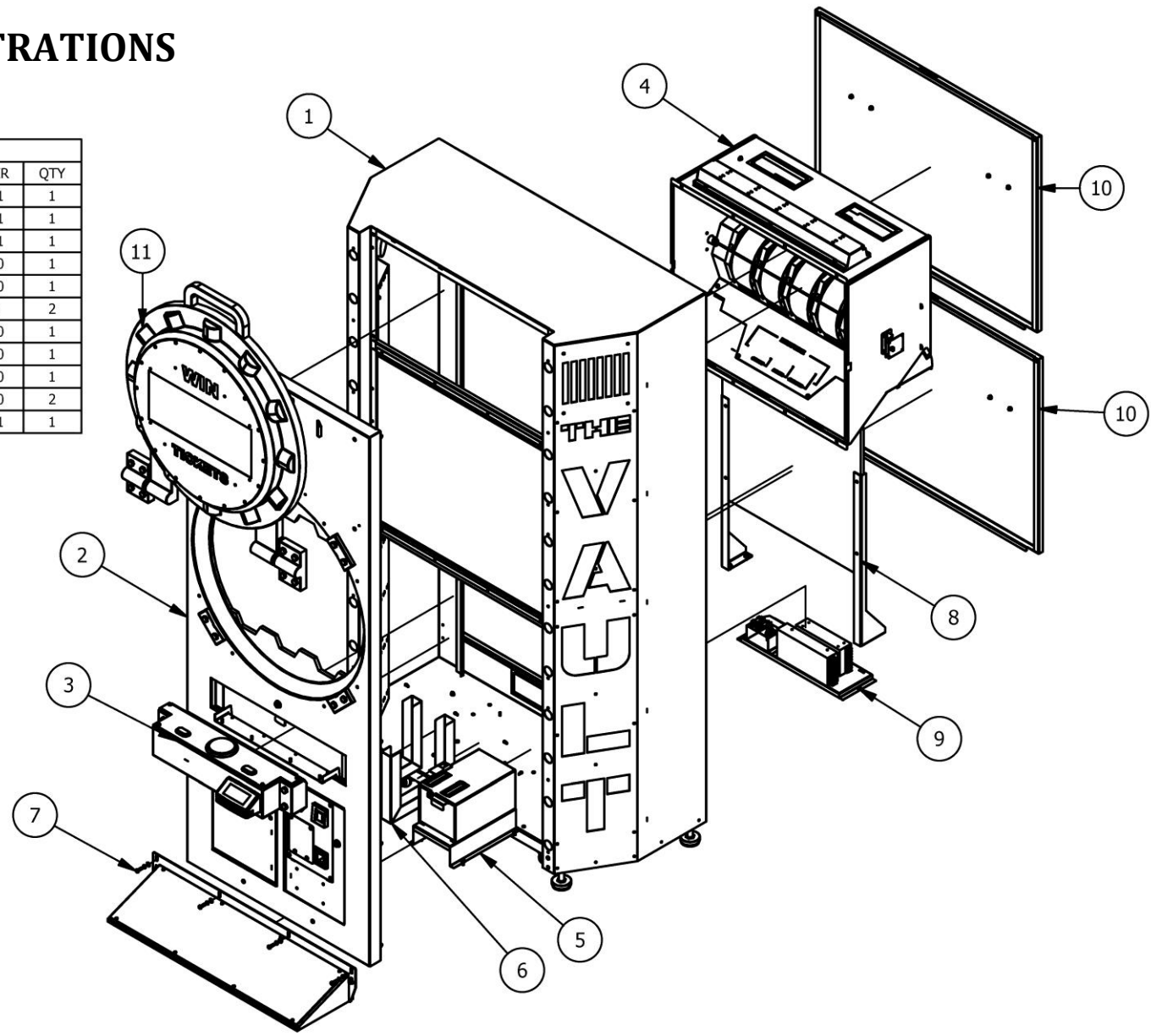

MAIN CABINET ASSEMBLY

Parts List			
ITEM	TITLE	PART NUMBER	QTY
1	Main Cabinet SA	SC1-SA-001-R1	1
2	Rubber Feet 16mm x 60 (Rubber Mounting)	HM3022	4
3	Roda Castor 2 " Double (Castor Wheel) SWIVEL with BRAKE YELMI LPK-50HHAB	HM0088	4
4	Acrylic Side Panel 1	SC1-FP-01-R0	2
5	Acrylic Side Panel 2	SC1-FP-02-R0	2
6	Acrylic Side Panel 3	SC1-FP-03-R0	6
7	Bracket LED Side Cabinet 1	SC1-FM-033-R0	2
8	Extention LED Side Cabinet 1	SC1-FM-054-R0	2
9	Bracket LED Side Cabinet 2	SC1-FM-034-R0	2
10	Extention LED Side Cabinet 2	SC1-FM-055-R0	2
11	Bracket LED Side Cabinet 3	SC1-FM-035-R0	6
12	Perforeted Side Speaker	SC1-FM-043-R0	2
13	The Vault - Speaker	SC1-ASSY-09-R0	2
14	The Vault - DB Box	SC1-ASSY-10-R0	1
15	Front Glass	SC1-FG-01-R0	1
16	Clamp Safety Glass	SC1-FM-037-R1	2
17	Kunci Lock Eangle (Lock and Key)	HM0004	2
18	Back door cam	SC1-FM-041-R0	2
19	Bracket Front LED Base	SC1-FM-015-R0	1
20	Bracket Side LED Base R	SC1-FM-016-R-R0	1
21	Bracket Side LED Base L	SC1-FM-016-L-R0	1
22	Plate Grounded	SC1-FM-050-R0	2
23	Serial Number Plate	SC1-FM-065-R0	1

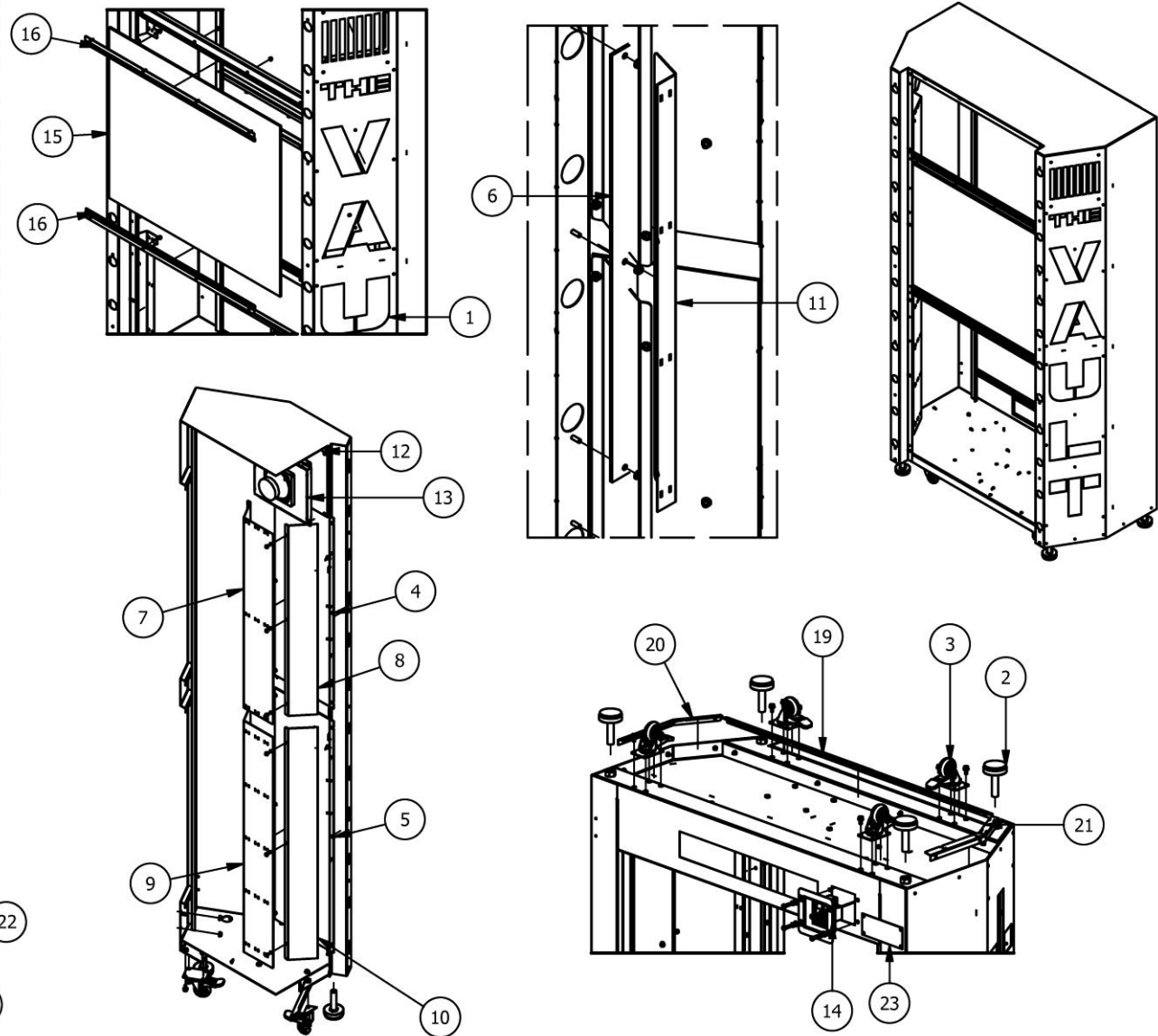

HEADER ASSEMBLY

Parts List			
ITEM	TITLE	PART NUMBER	QTY
1	Plastic Header	SC1-FP-05-R0	1
2	Plate Header	SC1-FM-048-R0	1
3	Acrylic 7Segmen Header	SC1-FP-07-R0	1
4	Spacer 7Segmen Header	SC1-FP-08-R0	4
5	PCB FB62 4 Digit 7 Segment 5" Display	BA1607	1
6	Acrylic Font WIN	SC1-FP-11-R0	1
7	Acrylic Prize Indicator	SC1-FP-12-R0	1
8	Box LED WIN	SC1-FM-042-R0	1
9	Box LED Ticket	SC1-FM-044-R0	1
10	Partition Round LED Header	SC1-FM-062-R0	4
11	Plate Base Header SA	SC1-SA-051-R0	1

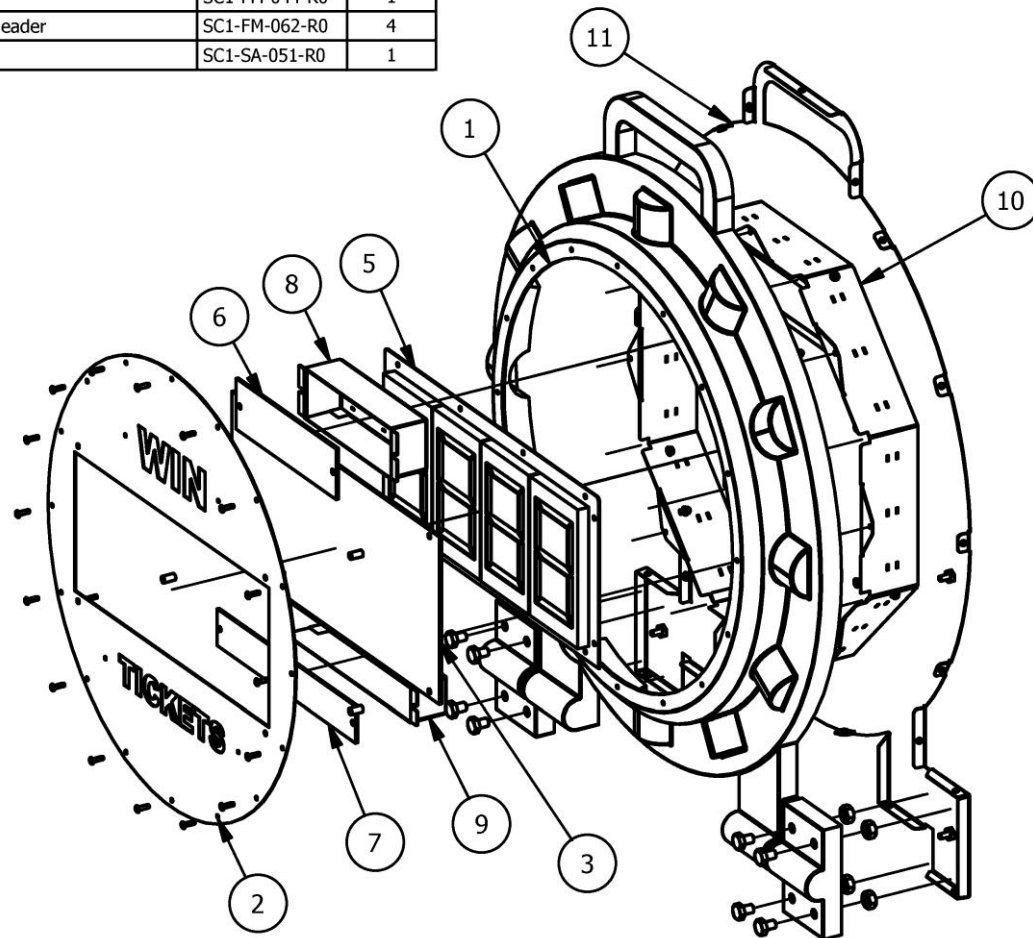

CABINET FRONT ASSEMBLY

Parts List			
ITEM	TITLE	PART NUMBER	QTY
1	Front Cabinet SA	SC1-SA-002-R1	1
2	The Vault - Coin Door	SC1-ASSY-16-R0	1
3	The Vault - Ticket Door	SC1-ASSY-17-R0	1
4	Kunci Lock Eangle (Lock and Key)	HM0004	1
5	Plate Grounded	SC1-FM-050-R0	1
6	Cam Control Panel	SC1-FM-046-R1	1
7	Plastic Playfield	SC1-FP-04-R0	1
8	Bracket LED Playfield SA	SC1-SA-013-R0	4

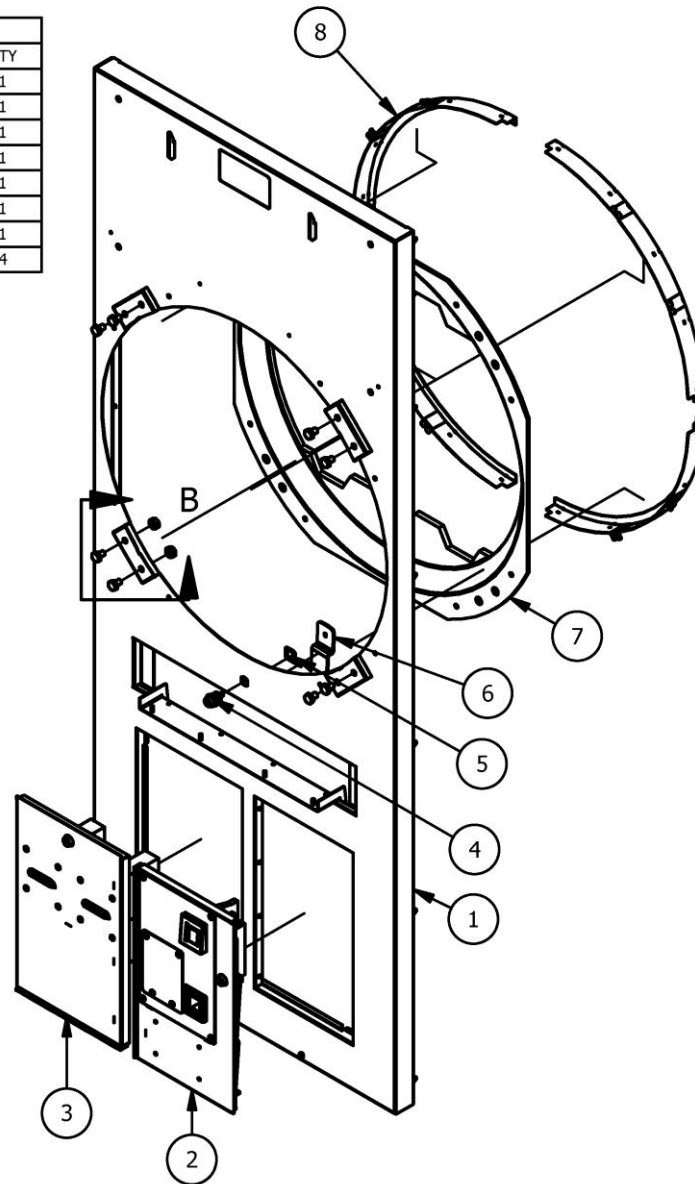

REEL MECHS ASSEMBLY

Parts List			
ITEM	TITLE	PART NUMBER	QTY
1	Box Playfield SA	SC1-SA-003-R1	1
2	Cover Acrylic Playfield	SC1-FP-09-R0	1
3	LED Bracket	SC1-FM-038-R0	1
4	Cover laser Pointer L SA	SC1-SA-011-L-R0	1
5	Cover laser Pointer R SA	SC1-SA-011-R-R0	1
6	Bracket PCB LED Pointer	SC1-FM-053-R0	2
7	Laser Rope Polystripe Optic 35	Polystripe35	1
8	Clamp Laser Rope	SC1-FM-056-R0	2
9	PCB FB155 LED Playfield	BAFB155	2
10	Acrylic Upper Instruction	SC1-FP-18-R1	1
11	Acrylic Lower Instruction	SC1-FP-17-R1	1
12	Acrylic Partition 1	SC1_FP-25-R0	6
13	Acrylic Partition 2	SC1_FP-27-R0	6
14	Bracket LED Partition	SC1_FM-064-R0	6
15	Base Reel Mech	SC1-FM-057-R1	1
16	Reel Mech Bracket C-19-22-0017	C-19-22-0017	5
17	Reel mach GS-1 79,5 12V V90° LED SMD W/Connector (Industrias Lorenzo, S.A.)	A197266021SGIL	5
18	Acrylic Display Prize	SC1_FP-22-R0	1
19	PCB51 2cm 4 Digit Display	Mini Display	2
20	Acrylic Upper Arrow	SC1_FP-23-R0	1
21	Box LED Arrow Playfield SA	SC1_SA-014-R0	1
22	Assy Life Light	SC1-ASSY-19-R0	1

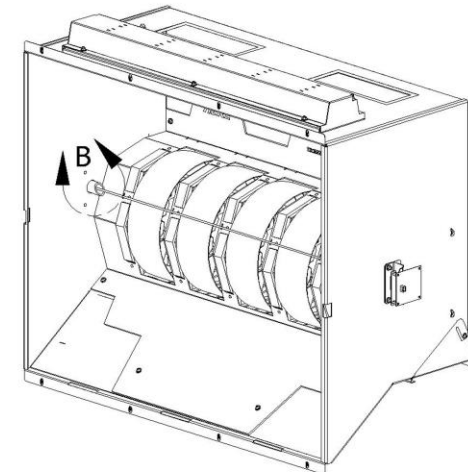
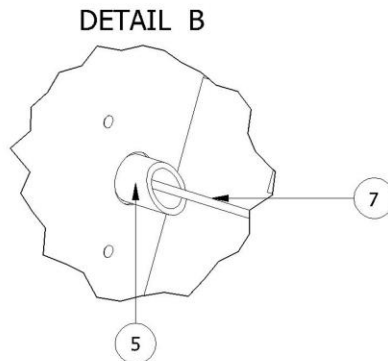
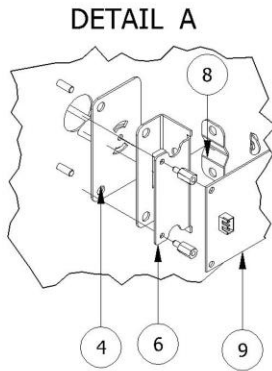
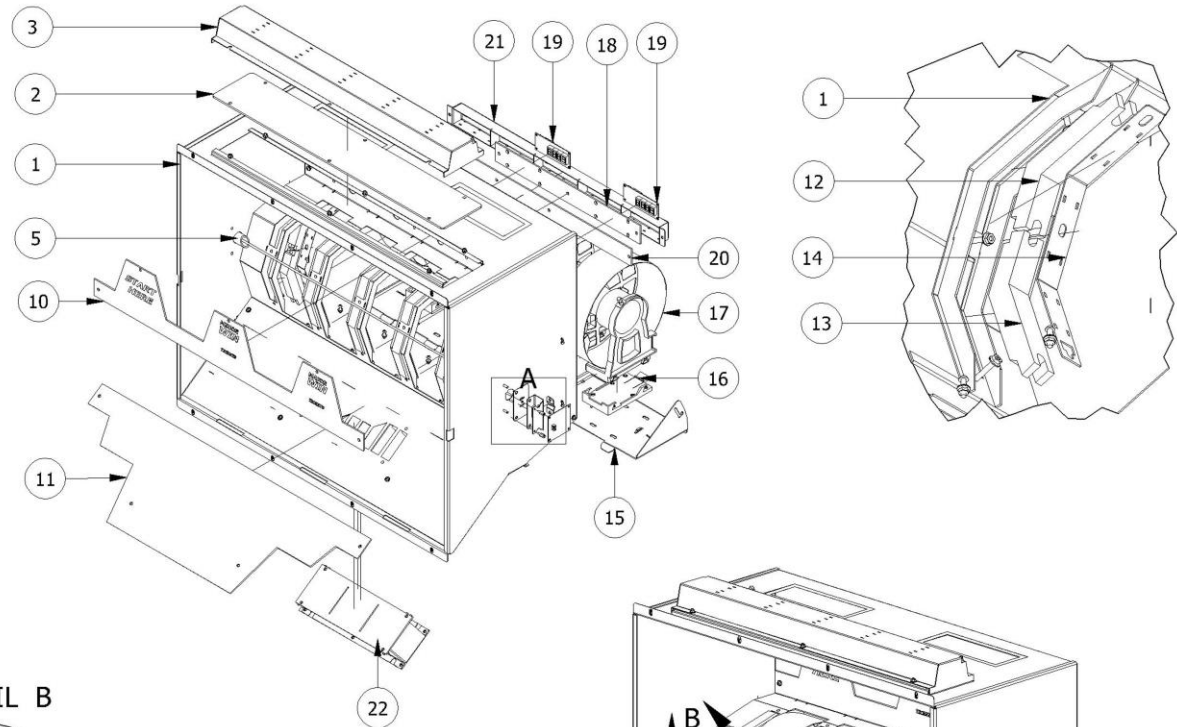

PCB PANEL ASSEMBLY

Parts List			
ITEM	TITLE	PART NUMBER	QTY
1	PCB Board	SC1-FW-01-R1	1
2	Bracket PCB Board Left	SC1-FM-021-L-R0	1
3	Bracket PCB Board Right	SC1-FM-021-R-R0	1
4	Sound Amplifier Board	FB106	1
5	48 I/O Board	FB162B	1
6	Extended Mode Controller Rev A	BA0045 / FB66	1
7	Ninefold Reel Mech Driver Board Revisi 2.0	FB201	1
8	Multiplexer	FB204	1
9	RGB Controller Rev 1.4	FB190	1
10	LM2596S DC-DC Adjustable step-Down power suply module	LM2596S DC	1

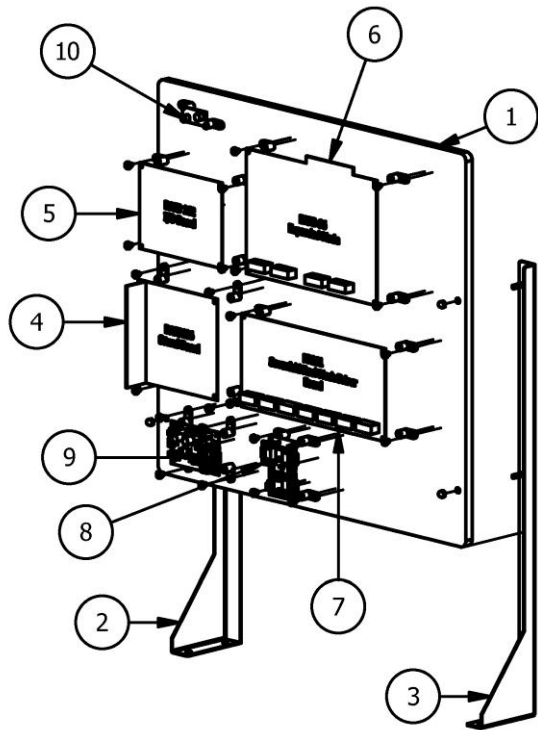

CONTROL PANEL ASSEMBLY

Parts List			
ITEM	TITLE	PART NUMBER	QTY
1	Control Panel SA	SC1-SA-004-R0	1
2	Hinge Control Panel	SC1-FM-045-R0	1
3	Acrylic Control Panel	SC1-FP-06-R1	1
4	Switch Large Mega Button Dome RED Led	EA0369	1
5	Button Oval Yellow Colour (RS-88)	EA1455	1
6	Button Oval Blue Colour (RS-88)	EA1454	1
7	LCD Character Display Modules & Accessories STN-BLUE Transm 122.0 x 44.0	EA1044	1
8	Cover Swiper Card	SC1-FM-61-R0	1
9	The Vault - Operator Panel	SC1-ASSY-08-R0	1

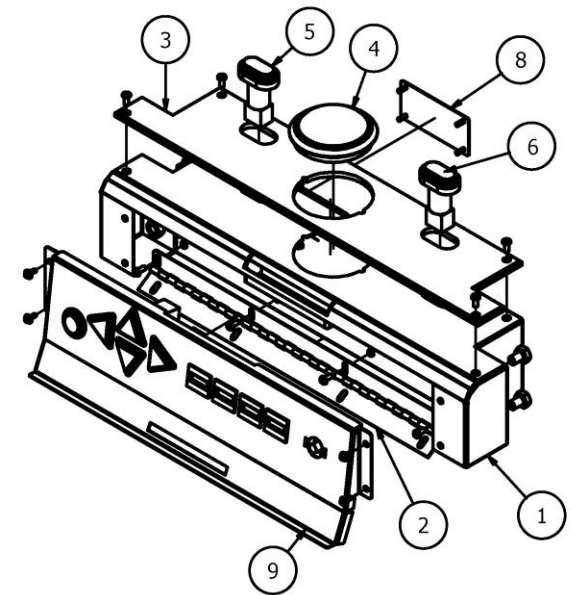

DB BOX ASSEMBLY

Parts List			
ITEM	TITLE	PART NUMBER	QTY
1	DB box front	SC1-FM-018-R0	1
2	DB box housing	SC1-FM-019-R0	1
3	IEC type EMI Filter with Fuse and Switch UL model : Delta 06AB25	EA0649	1
4	Binding Post (for New DB Box)	EA1356	1

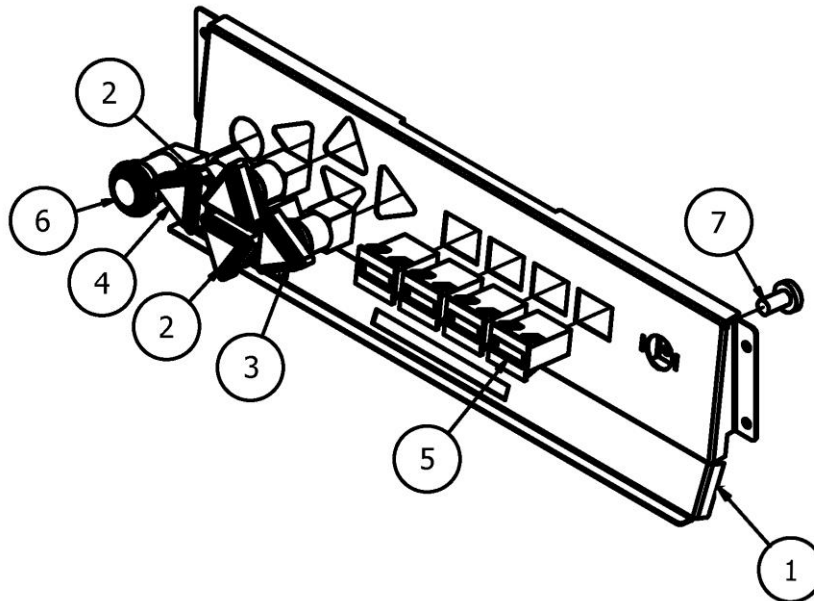
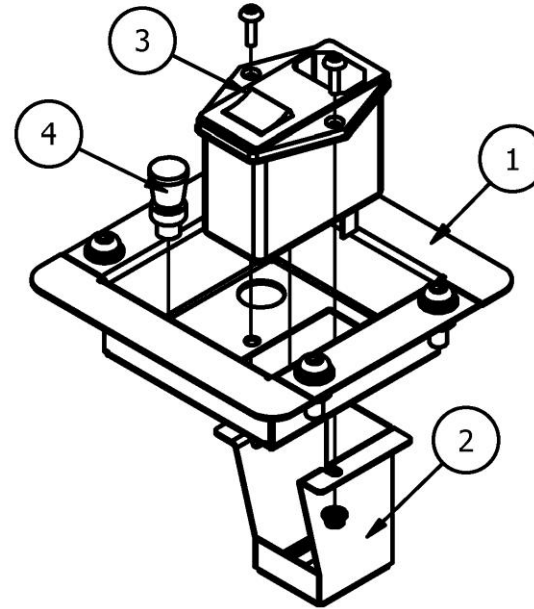

OPERATOR PANEL ASSEMBLY

Parts List			
ITEM	TITLE	PART NUMBER	QTY
1	Bracket Service SA	SC1-SA-010-R0	1
2	Switch Button Triangle CW-408 Blue	EA0588	2
3	Switch Button Triangle CW-408 Green	EA0590	1
4	Switch Button Triangle CW-408 Red	EA0589	1
5	Coin Counter 12v Rear Mounting (Bracket)	EA 1252	4
6	Switch Small Round White Button P/N : HS-02 M5	EA0521	1
7	Potentiometer Carbon Duel Gang 50K ohm	EE0689	1

CASH BOX ASSEMBLY

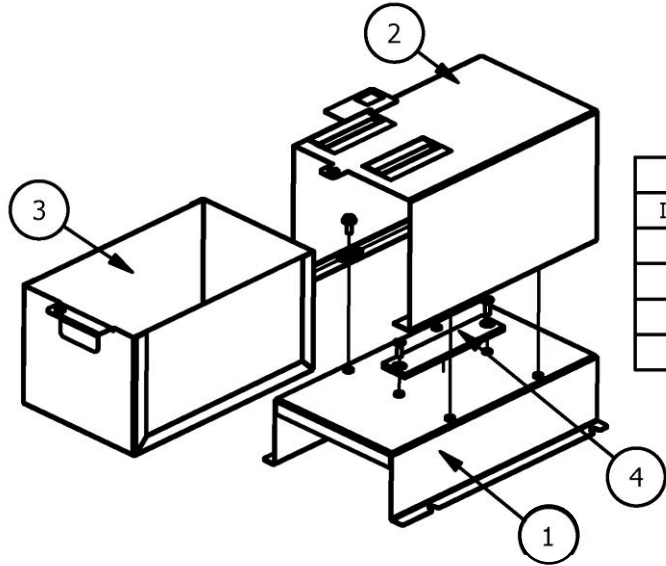

Parts List			
ITEM	TITLE	PART NUMBER	QTY
1	Base Cash Box	SC1-FM-032-R1	1
2	Housing Cash Box SA	SC1-SA-007-R0	1
3	Cash Box SA	SC1-SA-006-R0	1
4	Spacer Cash Box	SC1-FP-10-R0	1

SPEAKER ASSEMBLY

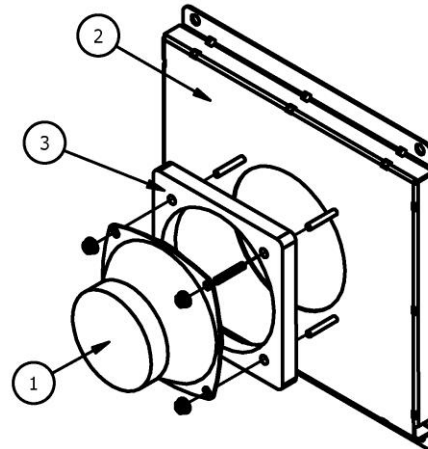

Parts List			
ITEM	TITLE	PART NUMBER	QTY
1	Speaker 4 ohm 50 watt prestige 1023	EA1206	1
2	Bracket Speaker	SC1-FM-036-R0	1
3	Spacer Speaker	SC1-FW-02-R0	1

LIFE LIGHT BOX ASSEMBLY

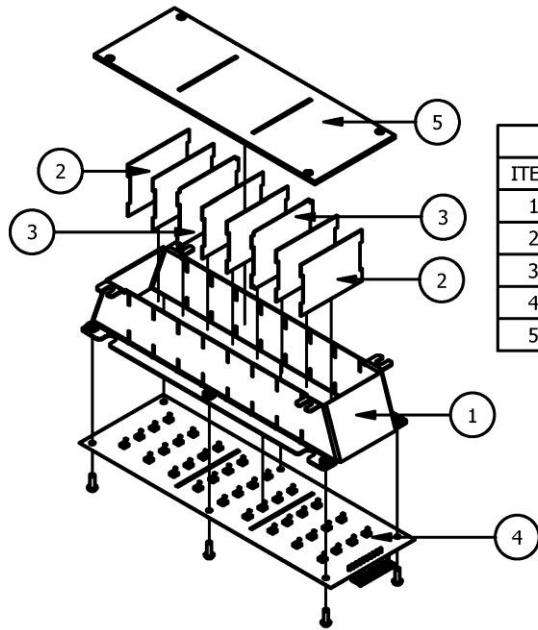

Parts List			
ITEM	TITLE	PART NUMBER	QTY
1	Box Life Light	SC1-FM-012-R0	1
2	Partition Life Light 1	SC1-FP-20-R0	6
3	Partition Life Light 2	SC1-FP-21-R0	2
4	Life Light	FB207	1
5	Acrylic Life Light	SC1-FP-15-R0	1

POWER SUPPLY ASSEMBLY

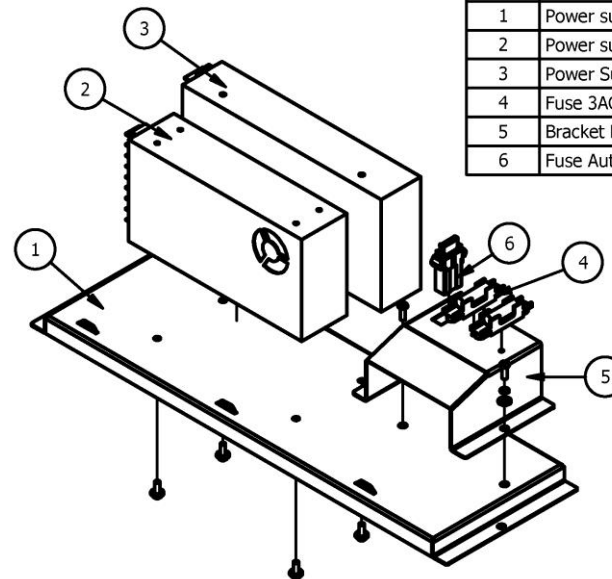

Parts List			
ITEM	TITLE	PART NUMBER	QTY
1	Power supply bracket	SC1-FM-020-R1	1
2	Power supply 25A SP-320-24 (MEANWELL)	EA1039	1
3	Power Supply 25A SP-320-12 (MEANWELL)	EA1039A	1
4	Fuse 3AG Slow Blow 5A	EA0032	2
5	Bracket Fuse Otomotif	SC1-FM-052-R0	1
6	Fuse Automotive 10A PN : 576-0287010.PXCN	EA0093	1

KICK PLATE ASSEMBLY

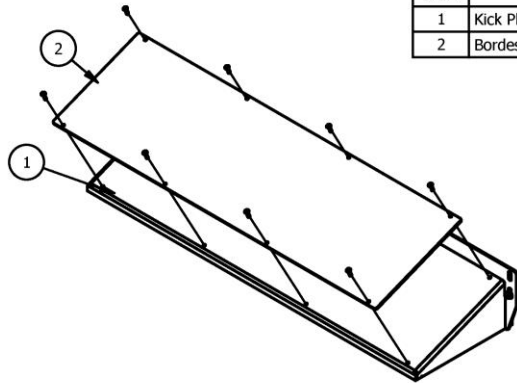

Parts List			
ITEM	TITLE	PART NUMBER	QTY
1	Kick Plate SA	SC1-SA-009-R0	1
2	Bordes Kick Plate	SC1-FM-017-R0	1

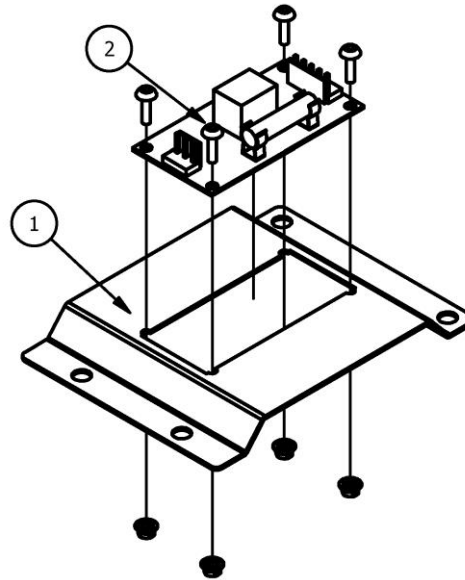

RELAY 12VDC ASSEMBLY

Parts List			
ITEM	TITLE	PART NUMBER	QTY
1	Bracket FB86 Relay VDC	SC1-FM-039-R0	1
2	Relay Board	FB86	1

COIN DBA PLATE ASSEMBLY

Parts List			
ITEM	TITLE	PART NUMBER	QTY
1	Coin DBA bracket	SC1-FM-024-R0	1
2	Cover DBA	SC1-FM-027-R0	1
3	Coin mechanism Holder Assy Single P/N. A07H02341000000	HA 0014	1

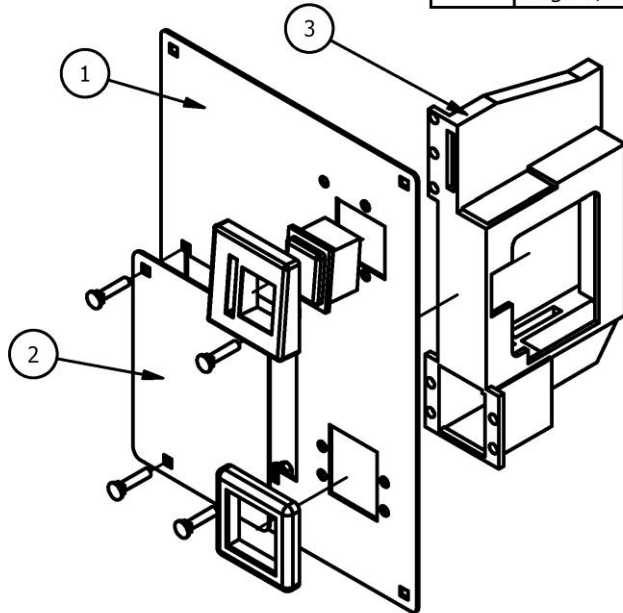

BACK DOOR ASSEMBLY

Parts List			
ITEM	TITLE	PART NUMBER	QTY
1	Back Door SA	SC1-SA-008-R0	1
2	Back Door Handle	SC1-FM-047-R0	2

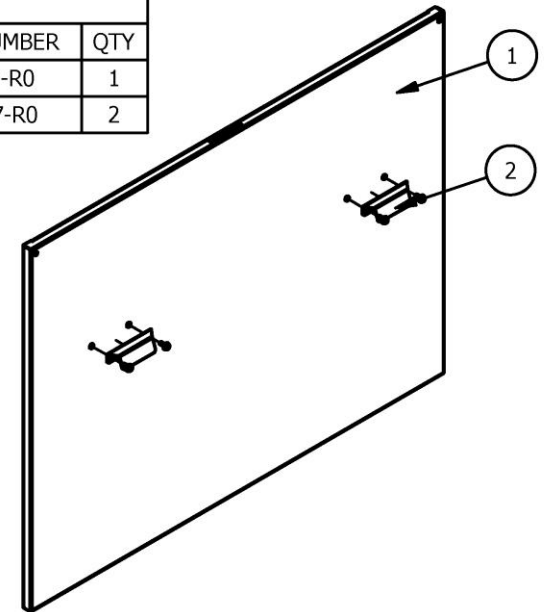

COIN DOOR ASSEMBLY

Parts List			
ITEM	TITLE	PART NUMBER	QTY
1	Coin Door SA	SC1-SA-005-R0	1
2	The Vault - Coin DBA Plate	SC1-ASSY-15-R0	1
3	Hinge Coin Door	SC1-FM-029-R0	1
4	Key Lock Eangle	HM0004	1
5	Plate Grounded	SC1-FM-050-R0	1
6	Cam Lock	SC1-FM-040-R0	1
7	Triple Lock Coin Door 1	SC1-FM-030-R0	1
8	Triple Lock Coin Door 2	SC1-FM-031-R1	1
9	The Vault - Relay 12 VDC	SC1-ASSY-18-R0	1

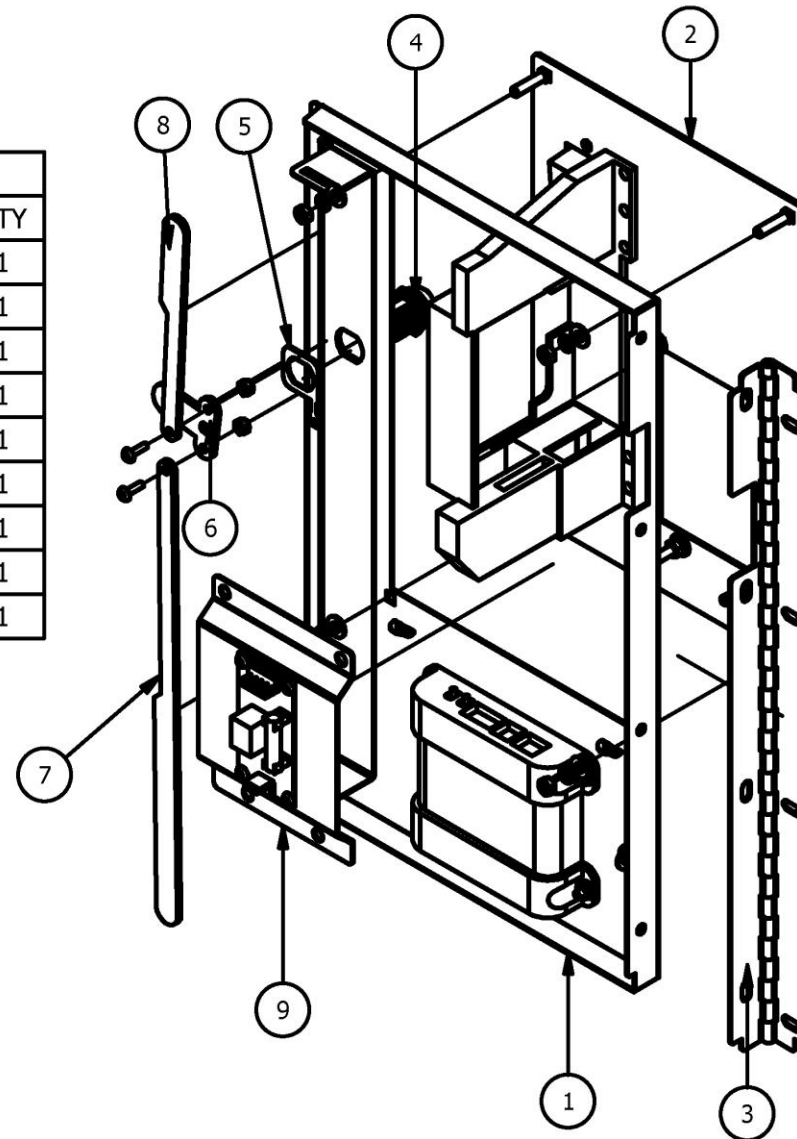

TICKET DOOR ASSEMBLY

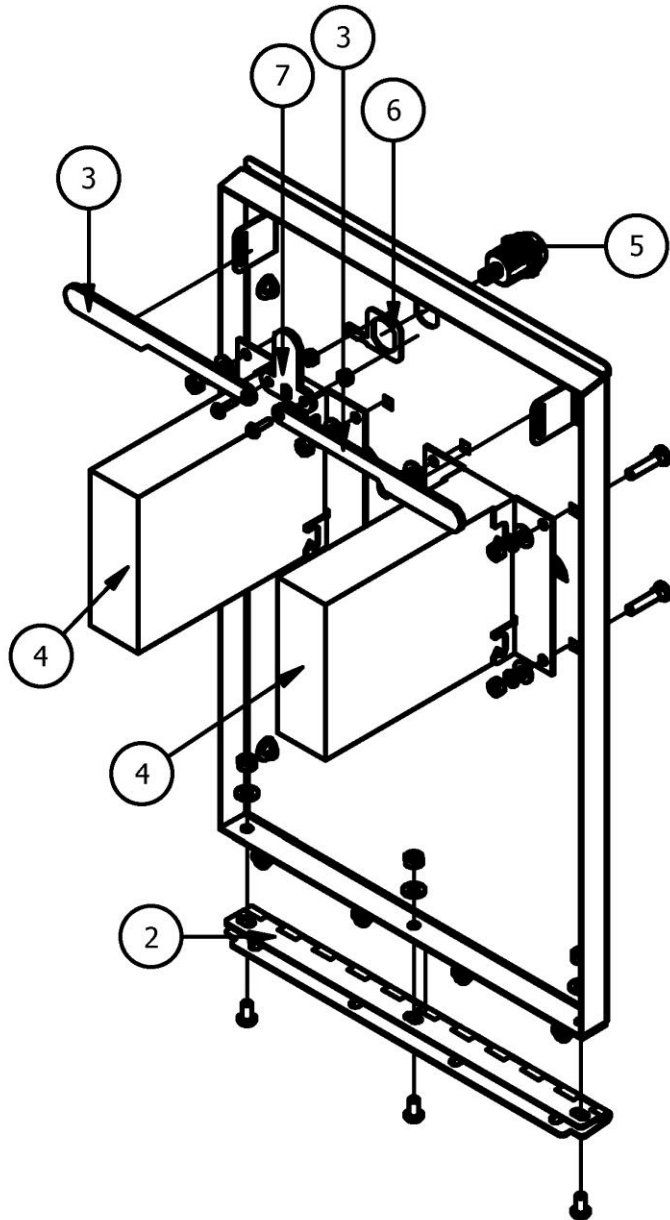

Parts List			
ITEM	TITLE	PART NUMBER	QTY
1	Ticket Door SA	SC1-SA-023-R0	1
2	Hinge Ticket Door	SC1-FM-028-R0	1
3	Triple Lock Coin Door 2	SC1-FM-031-R1	2
4	Ticket Dispenser DL-1275 ELECTRONIC LABS INC	EA 1103	2
5	Key Lock Eangle	HM0004	1
6	Plate Grounded	SC1-FM-050-R0	1
7	Cam Lock	SC1-FM-040-R0	1

Disclaimer

OPERATOR WILL TAKE NOTE

By accepting delivery of and placing this hardware and licensed software into operation, the Operator represents and warrants that it will only operate the hardware and licensed software provided by LAI Games in compliance with the regulatory requirements of the country, state, and/or municipality in which the hardware and licensed software are used and/or operated. LAI Games has provided this hardware and licensed the software **only** for legitimate and legal use, and any use of the hardware and licensed software in a manner that violates any laws of the country, state, and/or municipality in which the hardware and licensed software are used and/or operated is wholly unauthorized and shall be at Operator's sole and complete risk.

Operator assumes any and all risk and liability for any civil or criminal legal claims or causes of action arising from the unauthorized use and/or operation of the provided hardware and licensed software, such improper and unauthorized use specifically including, but not limited to:

- (a) Operating or allowing the operation of the hardware and licensed software in a manner that violates the laws and regulations of the country, state, and/or municipality in which the hardware and licensed software are used or operated;
- (b) Assembling or causing the assembly of the hardware in a manner not authorized by or disclosed in this manual;
- (c) Any tampering with, changes to, or modifications of the licensed software that occur after the software leaves LAI Games' factory that is not made by authorized LAI Games personnel and that is directly or indirectly caused by Operator; and
- (d) Any tampering with the computer chip/electronic programmable read only memory (EPROM) by or on behalf of Operator that directly or indirectly causes the tamper-indicating holographic seal on the computer chip/EPROM to be broken or damaged in any way.

LAI Games shall have no liability related to such improper and unauthorized use and/or operation of the hardware and licensed software, and Operator shall indemnify, defend, and hold LAI Games harmless for any claim or cause of action brought against LAI Games arising from Operator's or Operator's representative's improper and unauthorized use and/or operation of the hardware and licensed software.

Any improper and unauthorized use shall completely and totally void any and all warranties, both express and implied, of the hardware and licensed software provided by LAI Games.

WARRANTY

LAI Games warrants its manufactured products for a period of 3 months inclusive of parts and labor from the date of sale.

LAI Games exclusive obligation is to repair any item with any defects as a result of faulty workmanship or materials, providing the defective item or items of equipment are returned to the LAI Games distributor from which the machine was purchased.

LAI Games shall have no obligation to make repairs necessitated by negligence or interference to any component by any unauthorized personal. This will automatically void any existing warranty.

IF MAKING A WARRANTY CLAIM:

- (a) A Copy of the sales invoice must accompany the claim.
- (b) To and from Transport and freight costs are not covered by the warranty.
- (c) Warranty is not transferable with the sale of a machine from one owner to another.





INTERNATIONAL SALES & SERVICE

Sales/Enquiries: sales@laigames.com
Tech. Support: productsupport@laigames.com
Website: www.laigames.com

A stylized world map in white outlines is centered on a grey grid background that represents a globe.

For your nearest LAI Games Distributor, visit our web site at
<http://www.laigames.com>

ISO 9001 CERTIFIED ORGANIZATION



ISO 9001: 2008 Cert No.17460